



Power Up Your Skills: Commercial Heat Pump Water Heater Training & Trade Fair



Pipe Trades
TRAINING CENTER

Wednesday, April 15, 2026
8:30am - 1:00pm

Brought to you by PG&E Energy Centers, Pipe Trades Center, and

nbi new buildings
institute

**Sponsored by PG&E Energy
Centers**

With participation from



"PGE" refers to Pacific Gas and Electric Company, a subsidiary of PG&E Corporation. ©2026 Pacific Gas and Electric Company. All rights reserved. These offerings are funded by California utility customers and administered by PG&E under the auspices of the California Public Utilities Commission. Pacific Gas and Electric Company 300 Lakeside Drive Oakland, CA 94612 USA.

1

Commercial Heat Pump Water Heater Training & Trade Fair

A few introductions

Presenter: Evan Green, Research Engineer, Ecotope

Moderators: Susan Harris, Joe Wachunas, and Noah Gabriel from New Buildings Institute

Special guests:

- Ehsan Arabian, PhD, Senior Energy Centers Tech Specialist, Pacific Gas and Electric Company
- Brian Murphy, Training Center Coordinator, Pipe Trades Center
- Representatives from

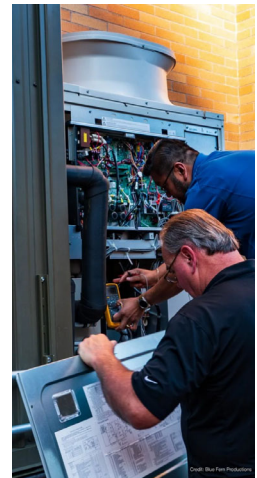

2

Event Schedule

- 8:30–8:50 AM – Coffee and brief meet & greet with manufacturers
- 8:50–9:00 AM – Everyone takes their seat
- 9:00 –10:45 AM – Presentation (with a mid-session break)
- 10:45 AM – 11:15 AM – Evan talks with manufacturers and conversation is streamed to all attendees
- 11:15 AM - 11:30 AM - Virtual attendees have Q&A time
- 11:15 AM – 12:00 PM – In person attendees have Q&A time and visit manufacturers
- 12:00 PM – 1:00 PM – Lunch with opportunities to visit with attendees and manufacturers

Event Survey Link and QR Code

<https://forms.gle/u7mD6zxrSAj1SEoh9>



3



WELCOME

Heat Pump Water Heaters: The Basics Every Pro Should Know

Evan Green

April 15, 2026



4

Disclaimer

The information in this document is believed to accurately describe the technologies addressed herein and are meant to clarify and illustrate typical situations, which must be appropriately adapted to individual circumstances. These materials were prepared to be used in conjunction with a free educational program and are not intended to provide legal advice or establish legal standards of reasonable behavior.

Neither Pacific Gas & Electric (PG&E) nor any of its employees and agents: (1) makes any written or oral warranty, expressed or implied, including but not limited to the merchantability or fitness for a particular purpose; (2) assumes any legal liability or responsibility for the accuracy or completeness of any information, apparatus, product, process, method, or policy contained herein; or (3) represents that its use would not infringe any privately owned rights, including but not limited to patents, trademarks or copyrights.

Furthermore, the information, statements, representations, graphs and data presented in this report are provided by PG&E as a service to our customers. PG&E does not endorse products or manufacturers. Mention of any particular product or manufacturer in this course material should not be construed as an implied endorsement.

5



Recording Authorization and Release

By attending this event you voluntarily and without compensation consent that Pacific Gas and Electric Company (PG&E), shall have the right to use and assign, photographic pictures, videotapes, recorded testimonials and other media materials or sound recordings, any and all of my name or likeness taken and acquired from our Energy Centers to use to promote or publicize PG&E's business.

Acceptable uses of such Information include but are not limited to: (1) advertising through video/audio commercial broadcasts, written advertisements or other promotional materials about PG&E, whether published by PG&E or another enterprise; (2) news stories or press releases supplied by PG&E to news gathering or disseminating organizations, such as wire services, newspapers, or magazines; and (3) publication in internal or external, PG&E publications.

By participating you agree to release and waive all claims against PG&E from any liability arising from using my Information. You also grant PG&E a perpetual, royalty-free, transferrable license to use my Information to promote its business and expressly disclaim all rights to any value and benefit PG&E may resulting from such use.

6

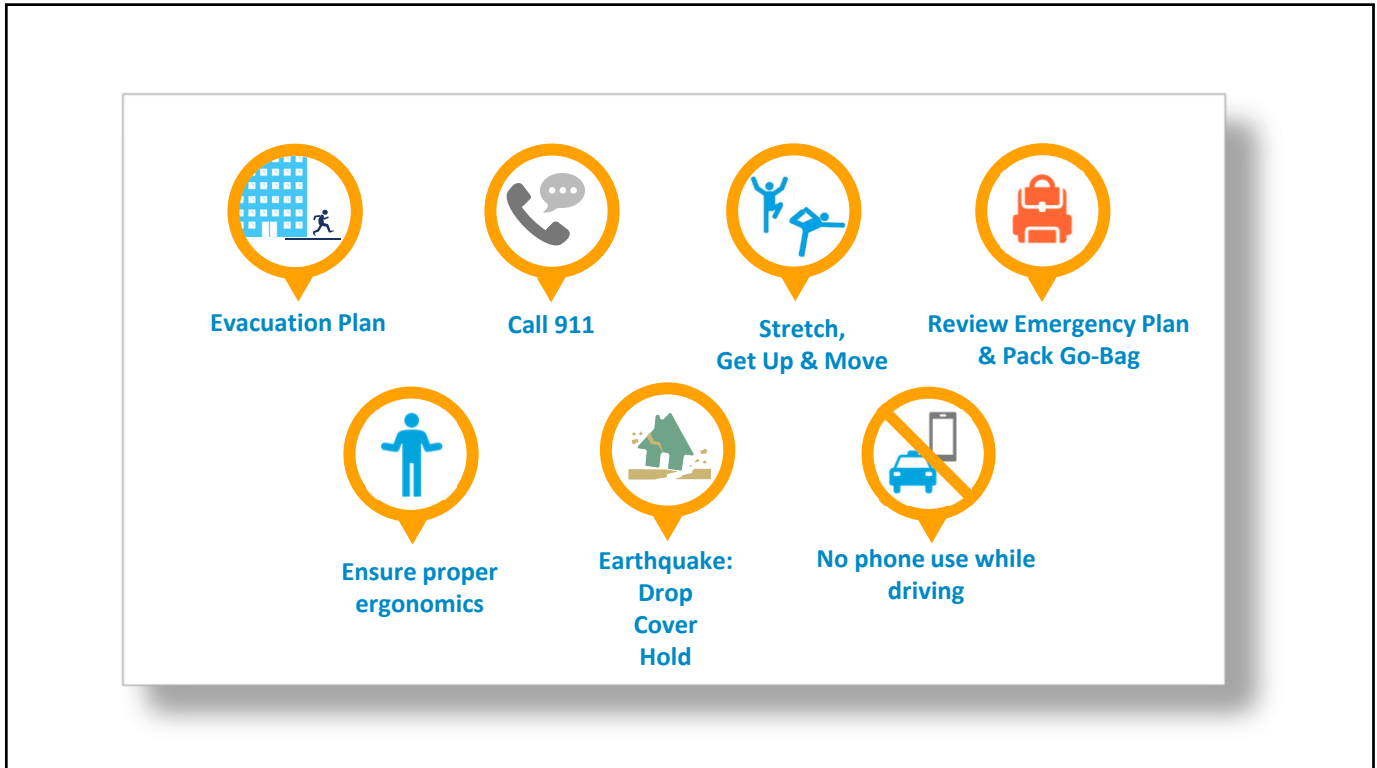

7

Class Survey coming...

At the end of this class, we'll share a class survey. We'd love to hear your feedback and if the class met your expectations.

Your comments will help us improve future classes.



8

Using GoTo Webinar

The image shows a GoTo Webinar interface with several callout boxes highlighting specific features:

- Chat, Questions, Materials, and Settings:** A callout box points to the top right of the webinar screen, showing icons for chat (3 messages), questions, materials, settings, and a menu.
- Chat:** A callout box points to the chat window, showing the word "Chat" and a text input field.
- Reactions and Hand Raising:** A callout box points to the bottom left of the webinar screen, showing icons for "Record" and "React".
- Leave:** A callout box points to the "Leave" button in the bottom center of the webinar screen.
- Closed Captions and Pop out:** A callout box points to the bottom right of the webinar screen, showing icons for "Caption" (with a "Beta" label) and "Pop out".

9

Heat Pump Water Heaters: The Basics Every Pro Should Know

Evan Green
Research and Design
Ecotope
Evan@ecotope.com

The Ecotope logo, featuring a yellow crescent moon and the word "ECOTOPE", is positioned above a stylized blue and white city skyline.

10

Agenda

**What is a CHPWH system?
Component Considerations
CHPWH System Sizing
Market Delivery**



11

What is a CHPWH system?

**Heat Pump Water
Heater (HPWH)**

**Commercial Heat
Pump Water Heating
(CHPWH) System**



12

NEEA Advanced Water Heating Specification

Anchoring the industry.

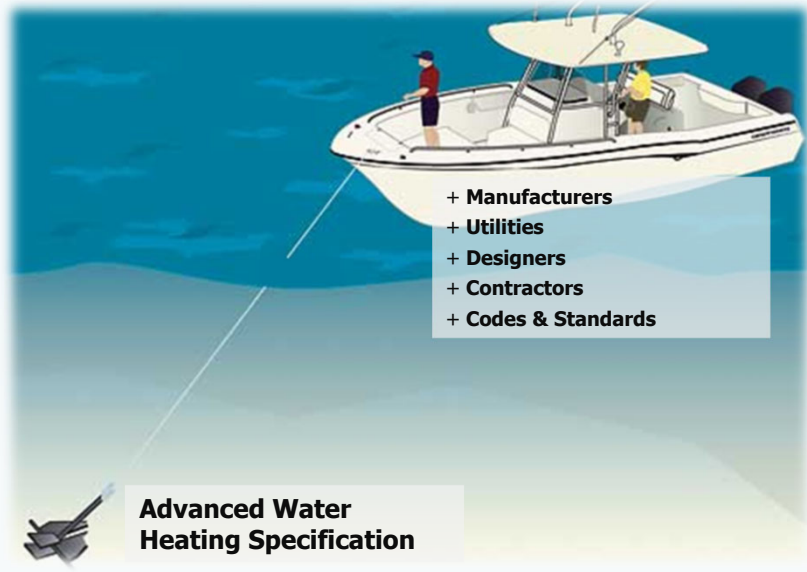

- + Manufacturers
- + Utilities
- + Designers
- + Contractors
- + Codes & Standards

Advanced Water Heating Specification

<https://nea.org/img/documents/Advanced-Water-Heating-Specification.pdf>



13

NEEA Qualified Products List

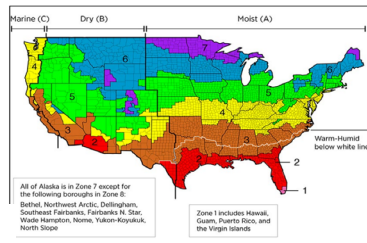

Table 1. HPWH System Efficiency Tiers

	Minimum SysCOP			
	Hot Climate (IECC Zones 1-2)	Mild Climate (IECC Zones 3-4)	Cold Climates (IECC Zones 5-6)	Extremely Cold Climates (IECC Zones 7-8)
Tier 1	1.75	1.50	1.25	1.15
Tier 2	2.25	2.00	1.60	1.50
Tier 3	2.75	2.50	2.25	2.15
Tier 4	3.50	3.00	2.75	2.50

Company	Identifier	Configuration	Market Delivery Method	Climate Zone				Ecopart	ANSI Z136.1 Performance Map	Performance Benchmarking				
				Hot Climate Tier	Mild Climate SysCOP	Cold Climate Tier	Very Cold Climate SysCOP							
Johnson Barrow with Colmac	CVA-25	Swag Tank	Fully Specified Bulk-tp	1	1.9	1	1.7	1	1.5	1	1.4	No	No	No
Johnson Barrow with Colmac	CVA-30	Swag Tank	Fully Specified Bulk-tp	1	1.9	1	1.7	1	1.5	1	1.4	No	No	No
Johnson Barrow with Colmac	CV-5	Swag Tank	Fully Specified Bulk-tp	1	2.1	1	2.0	2	1.9	2	1.7	No	No	No
Laars Heating Systems Company	ECHW325-A-XA-1-XXXX	Swag Tank	Fully Specified Bulk-tp	2	2.5	2	2.4	3	2.3	2	1.9	Yes	No	Yes
Lochinvar, LLC	All IPO50	Multi Pass Return to Primary	Custom Engineered	1	2.2	1	2.0	2	1.7	1	1.5	No	No	No
Lochinvar, LLC	AHP140	Multi Pass Return to Primary	Custom Engineered	1	2.1	1	1.9	2	1.7	1	1.5	No	No	No
Lochinvar, LLC	AHP200	Multi Pass Return to Primary	Custom Engineered	1	2.2	1	1.9	2	1.7	1	1.5	No	No	No
Lochinvar, LLC	AHP280	Multi Pass Return to Primary	Custom Engineered	1	2.1	1	1.9	2	1.7	1	1.5	No	No	No
Lochinvar, LLC	AHP350	Multi Pass Return to Primary	Custom Engineered	1	2.2	1	1.9	2	1.7	1	1.5	No	No	No
Mitsubishi Electric Trane US	HeatDO	Swag Tank	Fully Specified Bulk-tp	2	2.6	2	2.3	2	2.1	2	1.9	No	No	No
Nyle Water Heating Systems, Inc.	C185A	Swag Tank	Custom Engineered	1	2.0	1	1.7	1	1.5	1	1.4	No	No	No

<https://nea.org/img/documents/commercial-HPWH-qualified-products-list.pdf>

- + AWHs-compliant HPWH manufacturers
- + Efficiency (COP) ratings specific to:
 - + Piping configuration
 - + Full DHW plant energy usage
 - + Climate zone
 - + Multifamily DHW usage
- + Simple tier structure



14

Putting the "C" in CHPWH System

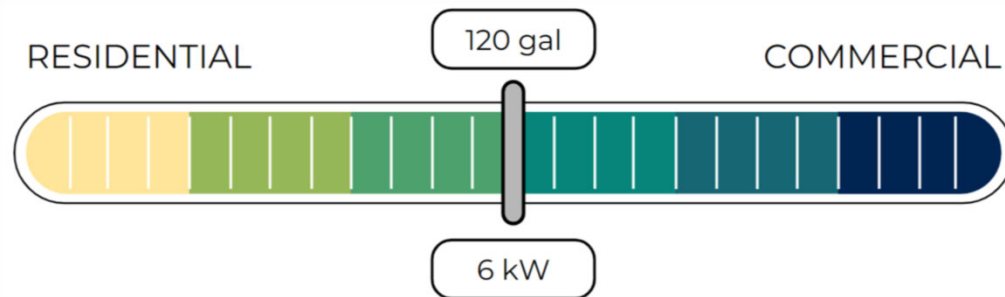

AWHS 3.2.1: Commercial systems are defined as those serving more than four dwelling units or serving commercial loads needing more than a total of 119 gallons of storage volume and/or more than 6 kW of input power.

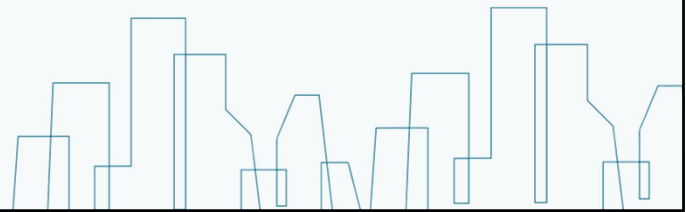

15

Let's check in:

1. Ever heard of the AWHS?
2. Any experience comparing CHPWH systems side-by-side? What is most useful?



16

Time to get technical.

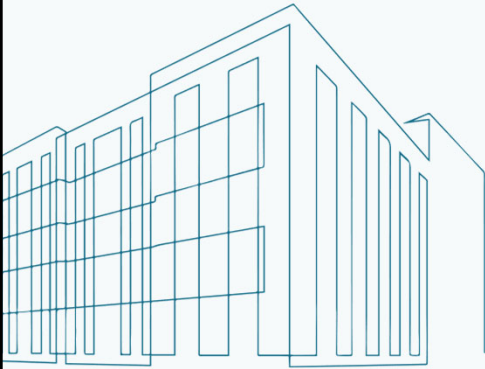

- CHPWH system components
- Understanding CHPWH System Components
 - HPWH
 - Storage
- Coffee Break
 - Temperature maintenance system
 - Controls
- System Sizing

17

CHPWH System Components

- + Primary heat pump water heater
- + Primary storage
- + Temperature maintenance system
- + Controls

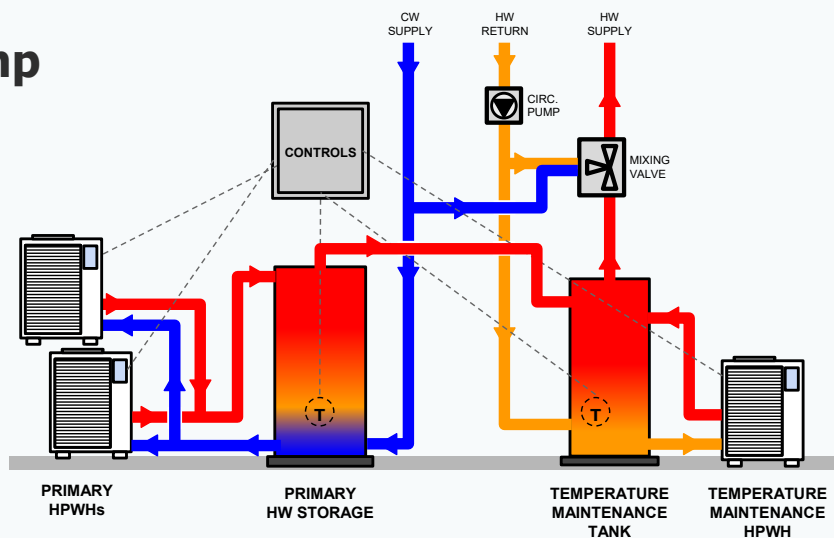

18

Primary HPWH

The heart of the system.

Types:

Single pass, multi pass, integrated

Performance:

- Capacity
- Coefficient of Performance (COP)
- Operating envelope
- Defrost

Refrigerants:

- Driver of performance
- Global warming potential



19

HPWH Types

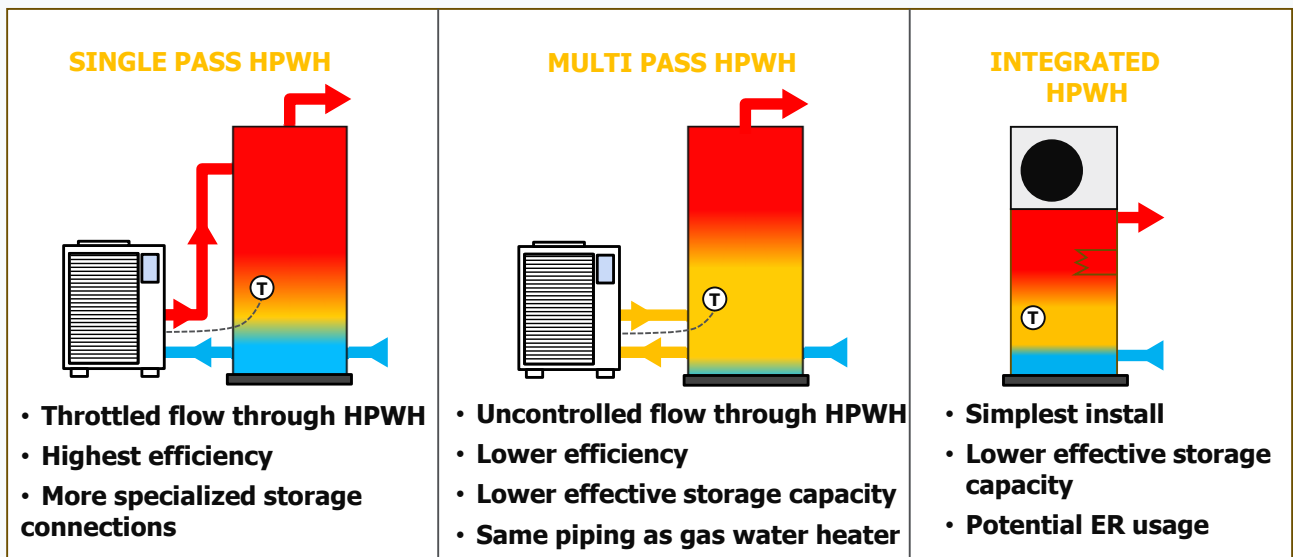

20

Single Pass Operation

1. Tank is fully charged, HPWH is off.

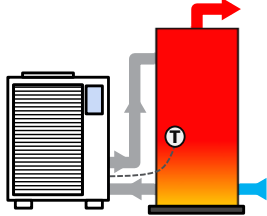

2. Building uses DHW, HPWH turns on.

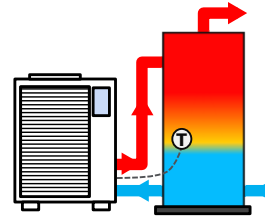

3. Building HPWH and storage satisfy peak DHW load.

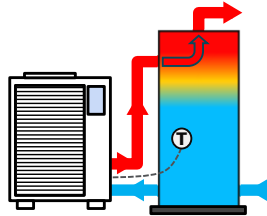

4. Peak DHW load subsides, HPWH recharges tank.

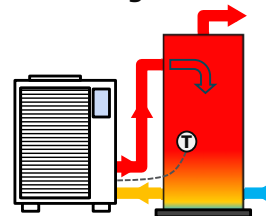

21

Multi Pass Operation

1. Tank is fully charged, HPWH is off.

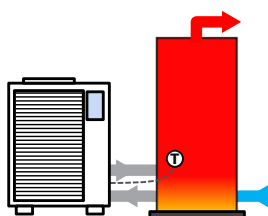

2. Building uses DHW, HPWH turns on.

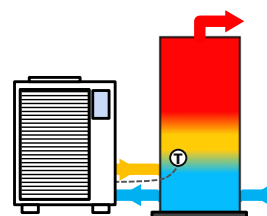

3. Storage satisfies peak load.

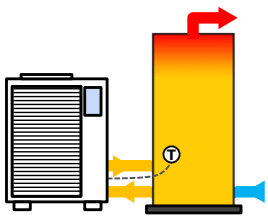

4. Peak DHW load subsides, HPWH recharges tank.

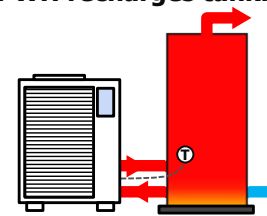

22

HPWH Operating Envelope

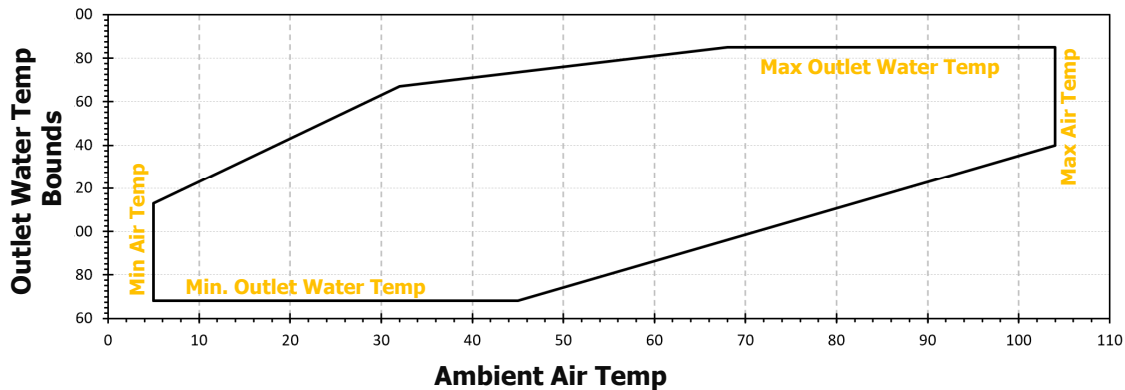

DO NOT REFERENCE THIS FOR DESIGN! ENVELOPE VARIES BY MFR.



23

HPWH Performance

Capacity:

- How much heat is provided?
- Units: BTU/h, kBTU/h, MBH, kW
- Impacted by air and water temperatures

Coefficient of Performance (COP):

- How efficiently is heat provided?
- $COP = \text{heat provided} / \text{energy used}$ (unitless)
- Impacted by air and water temperatures

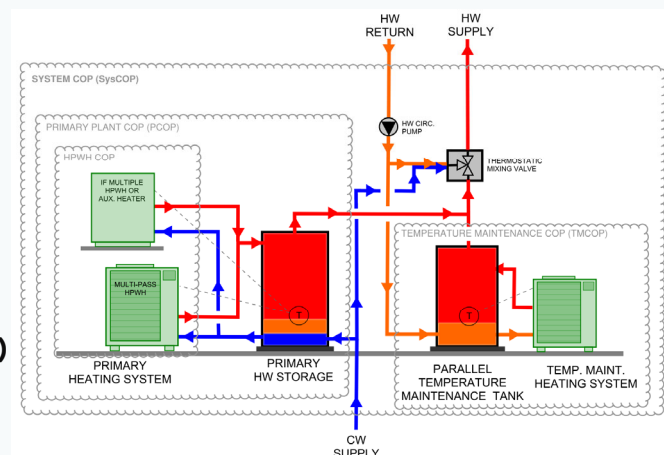

24

HPWH COP

HPWH COP vs Ambient Air Temp & Inlet Water Temp

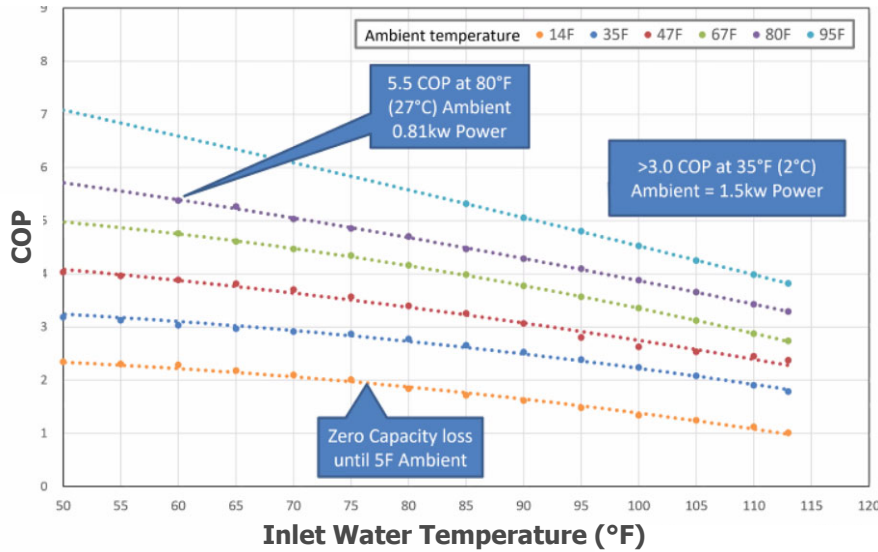

Warmer air:
Increases HPWH COP

Warmer inlet water:
Decreases HPWH COP*

Warmer outlet water:
Decreases HPWH COP*

*Many factors are refrigerant-specific.



25

HPWH Capacity

HPWH Capacity vs Ambient Air Temp & Inlet Water Temp

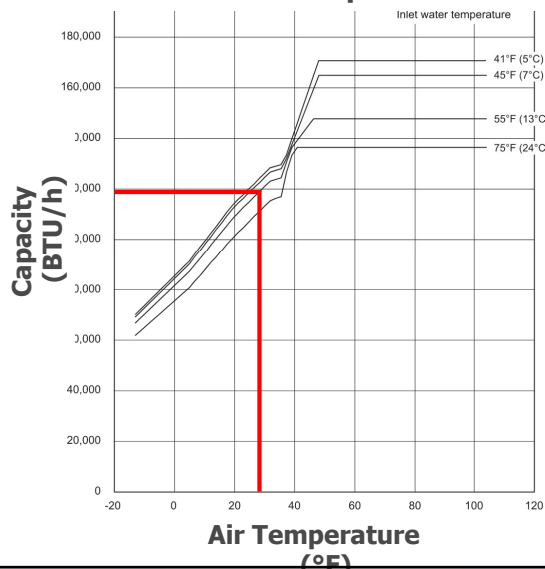

+ **Warmer air:**
Increases capacity

+ **Warmer inlet water:**
Variable capacity impact*

+ **Warmer outlet water:**
Negligible capacity impact

*Many factors are refrigerant-specific.



26

Refrigerants

Refrigerant type impacts every aspect of HPWH performance. Let's compare CO2 and R134a:

	R134a/R513A HPWH	CO2 HPWH
High inlet water temperature	Minor COP and capacity reduction. Capable of multi pass heating	Major COP and capacity reduction. Single pass heating only.
High outlet water temperature	Major COP reduction. Some models will produce up to 180°F in high ambient temps.	Minor COP reduction. Some models will produce up to 180°F in a wide range of ambient temps.
Low ambient air temperature	Will not operate below ~40°F air	Operates down to ~-20°F
High ambient air temperature	Major COP and capacity increase up to ~100°F air.	Minor COP and capacity increase above ~60°F air
Global warming potential	Very high GWP: 1300	Very low: 1
Phase out	2035 or sooner	Here to stay



27

But wait, there's Defrost!

- **Coil builds ice in air temps below ~45°F**
- **Various ways to melt this ice:**
 - **Electric resistance coils**
 - **Hot gas defrost**
 - **Reverse cycle**
- **Impacts COP and capacity to varying degrees.**

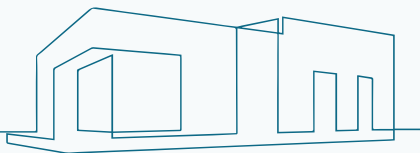

28

Let's check in:

1. Any questions about HPWH capacity and COP?
2. Have you seen an application where multi pass beats single pass?



29

DHW Storage

A HPWH's inseparable partner.



We'll focus on single pass:

- Storage functions
- Connection locations
- In-series vs parallel



30

Functional Volumes

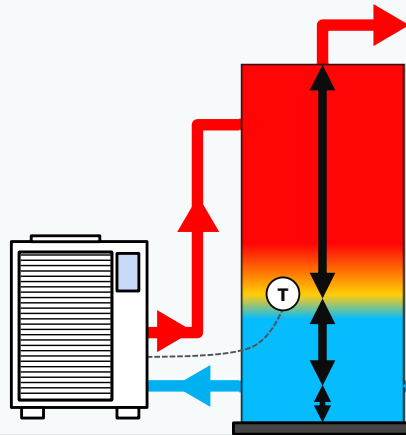

Running volume: helps HPWH satisfy peak DHW load.

Cycling volume: prevents HPWH from short-cycling.

Unusable volume: wasted space below HPWH connection.

Aquastat Fraction: $\frac{\text{Unusable volume} + \text{cycling volume}}{\text{total volume}}$

Drawdown %: $90\% - \frac{\text{unusable volume}}{\text{total volume}}$

31

Connection Locations

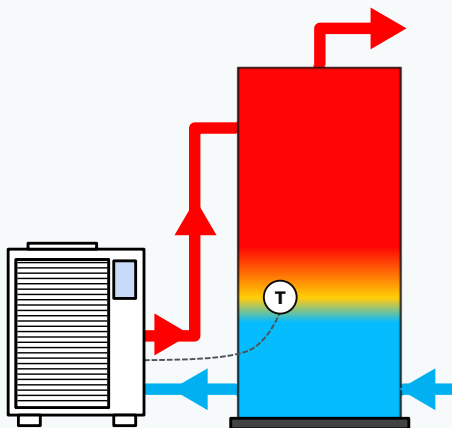

DHW Supply: top of tank or as high as possible.

HPWH Hot: as high as possible on side wall.

Thermowell: high enough to prevent short-cycling, low enough to maximize running volume.

HPWH Cold: As low as possible on side wall or bottom of tank.

DCW inlet: as low as possible on side wall (higher than HPWH cold if needed)

Note: Supply dedicated HPWH connections!

32

In-series Storage Tanks

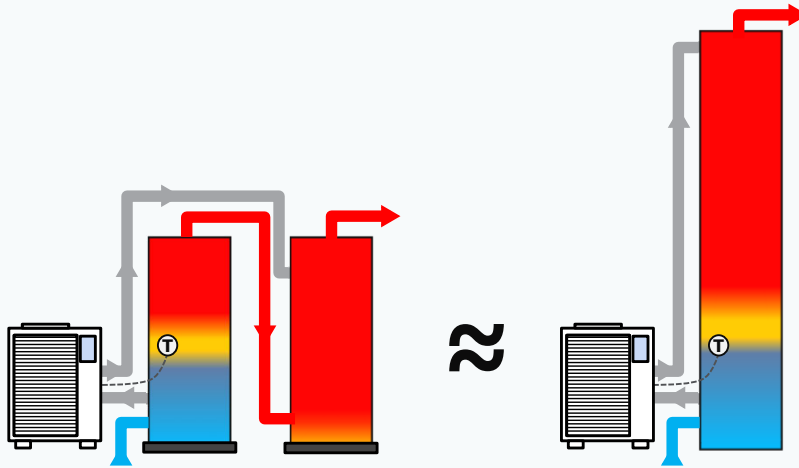

33

Parallel Storage Tanks

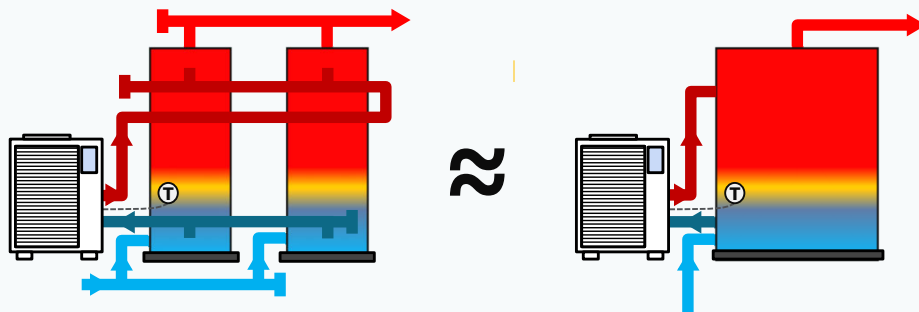

34

In-series vs Parallel Storage

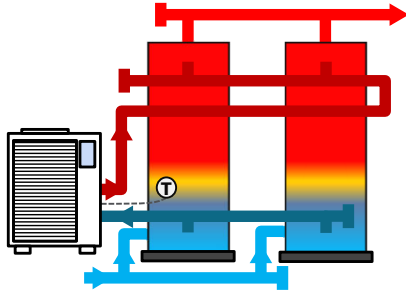

- Lower pressure drop
- Less granularity in thermowell height
- Higher effective storage capacity (?)
- More sensitive to imbalanced piping*

*stratified, parallel tanks are self-balancing in low flow periods.

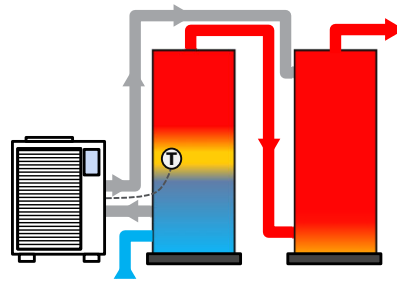

- Higher pressure drop
- More granularity in thermowell height
- Lower effective storage capacity (?)
- Very different from gas water heater piping



35

Let's check in:

1. Any questions about storage?
2. Any more important storage considerations?



36

Temperature Maintenance

Keeping the pipes **hot**.

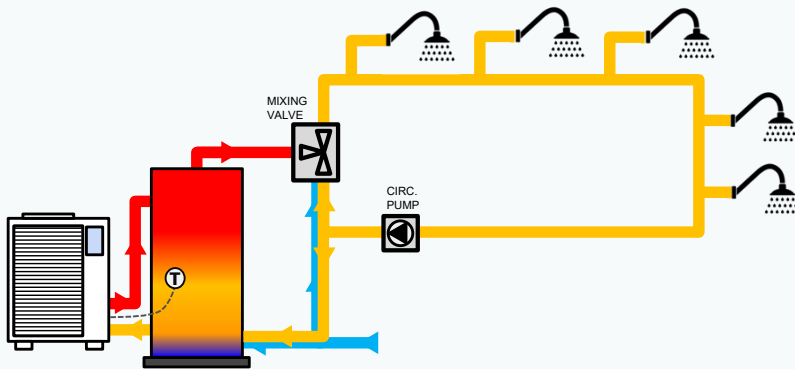

+ **Challenge: High HPWH inlet water temperature (IWT)**

+ **HPWH System Configurations:**

- + Return to primary
- + Swing configuration
- + Parallel loop configuration
- + Non-centralized

37

Return to Primary Configuration

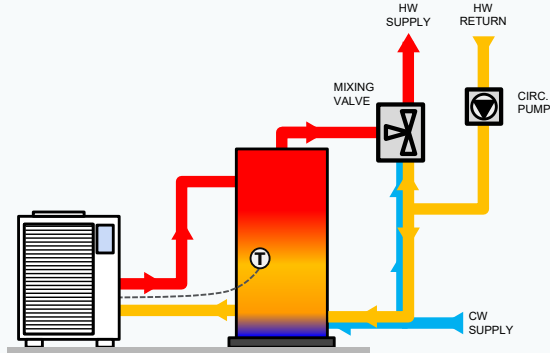

HPWH Requirements:

- Heat efficiently when IWT > 100°F
- Turn off when IWT > 130°F

Special Considerations:

- Minimize HWR temperature
- Place temp sensor high enough to prevent short-cycling

Pros: Lowest cost, familiar plumbing

Cons: Equipment specific, short-cycling risk

Best Application: medium-to-high recirc losses, manufacturer approved configuration

38

Parallel Loop Tank Configuration

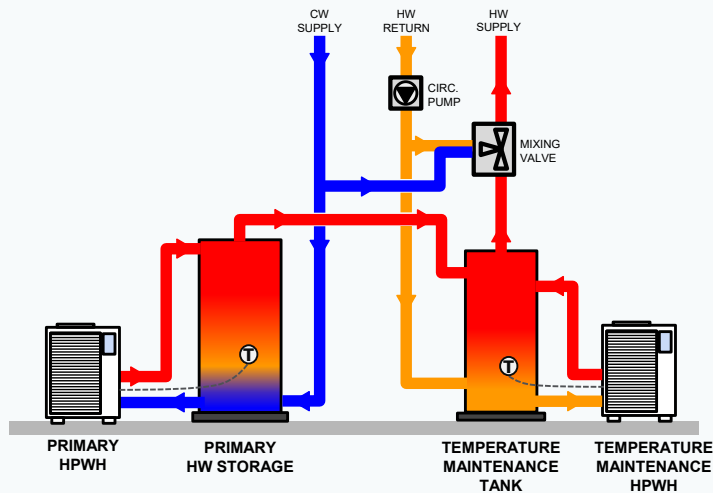

Primary HPWH Requirements:

- Heat efficiently when IWT > 60°F
- Turn off when IWT > 120°F

TM HPWH Requirements:

- Heat efficiently when IWT > 120°F
- Turn off when IWT > 130°F

Special Considerations:

- Careful with TM tank connections

Pros: Efficient primary HPWH operation

Cons: Highest cost/complexity

Best Application: high recirc losses, manufacturer approved configuration, load shift



39

Swing Tank Configuration

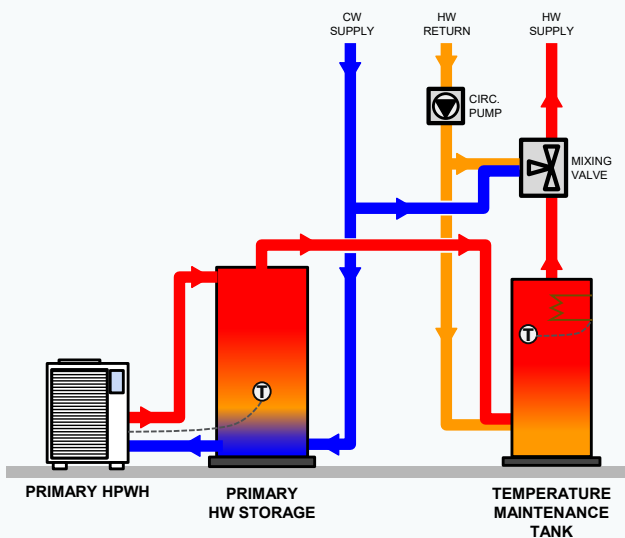

Primary HPWH Requirements:

- Heat efficiently when IWT > 60°F
- Turn off when IWT > 120°F

ER Heater nice-to-have:

- Staged heating
- Elements and sensor in upper-tank

Special Considerations:

- Careful with TM tank connections

Pros: Efficient primary HPWH operation, standard EWH or existing heater can be used as swing tank.

Cons: High cost/complexity, risk of high ER usage

Best Application: very low TM loss, retrofits

40

Non-centralized

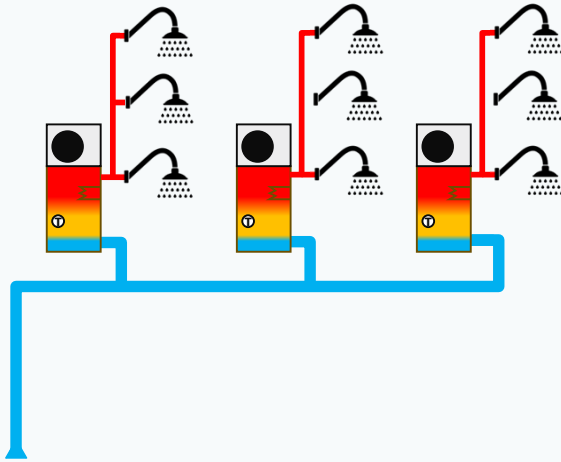

Primary HPWH Requirements:

- Heat efficiently when IWT > 60°F
- Low cost

Special Considerations:

- Space and source air for HPWHs near each cluster of dwelling units

Pros: No HWC loop

Cons: High cost, high space requirements

Best Applications: in-unit ER heater retrofits where source air is accessible, clusters of dwelling units.



41

Let's check in:

1. Any questions about temperature maintenance?
2. Which of these systems do you see most potential for?



42

Controls

How HPWHs communicate.



- + Key Functions
- + Levels of Control
- + Sample SOO

43

Controls – Key Functions

1. Turn equipment on and off
2. Monitor equipment status
3. Send alarms



System Alarm (14) - RCC-2 Global Alarm: ALARM



bms.alarm.distributor@gmail.com

● Evan Green

Source: (Device 100100) - System Alarm (14)
 RCC-2 Global Alarm
 Time of Alarm: 2022/Apr/26 07:58:24

44

Levels of Control

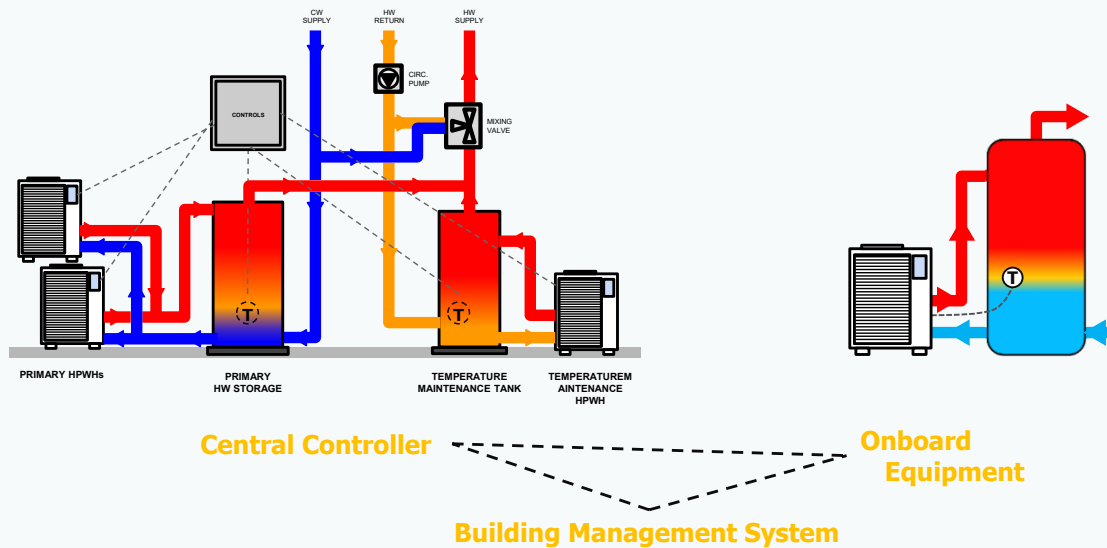

45

Sample Sequence of Operation

Primary HPWH:

Maintain 140°F HPWH outlet temperature in single pass mode.

Turn on when lower tank temp < 115°F.

Turn off when HPWH IWT > 125°F.

Tips:

- Include every DHW component.
- Consult with manufacturers.
- Label temperature sensors on schematic and in DHW plant to match SOO.

Swing Tank:

Maintain 125°F setpoint temperature.

Back-up heater:

Turn on when upper tank temp < 115°F

Mixing Valve:

Maintain 125°F delivery temperature.

HWC Pump:

Set to constant temperature: target 115°F

Monitoring:

HPWH status, alarms, and supply temperature shall be visible on local user interface.

Alarms:

Send alarm notification via email if:

Any HPWH is in alarm state.

DHW supply < 120°F

DHW return < 110°F

46

Let's check in:

1. Questions about controls and SOO?
2. Any more pointers?

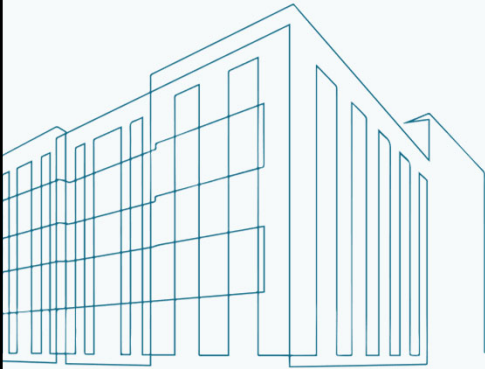

47

System Sizing

The whole day matters.

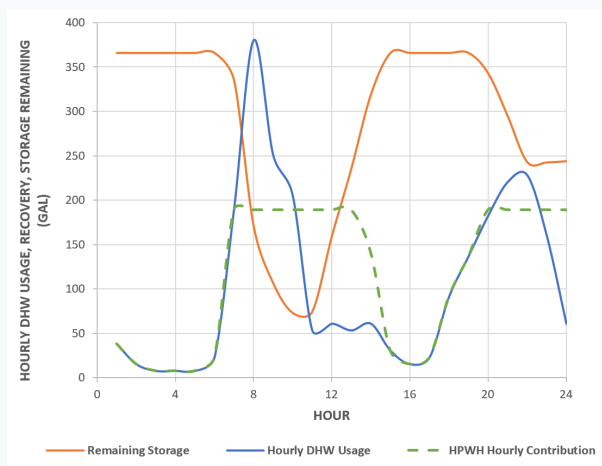

+ Sizing Logic

+ Ecosizer



48

Sizing Logic

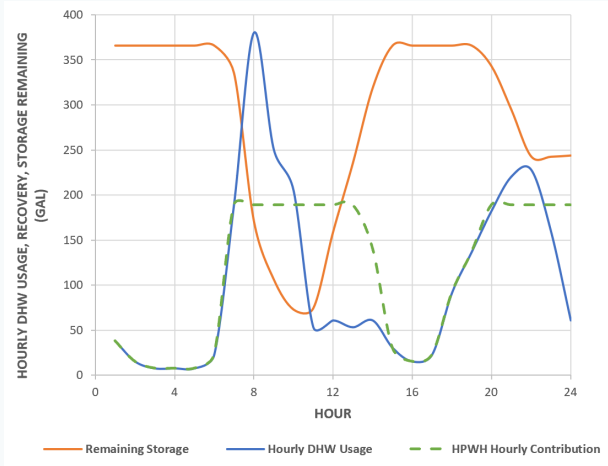

Define building characteristics: DHW usage profile and total daily DHW usage

Size HPWH to run ~16hrs/day to satisfy total daily DHW load. Remember to account for ambient air de-rate.

Size storage to satisfy peak DHW usage period with HPWH's help.



49

ECOSIZER

[Size Your System](#)
[TECH-HPWH Calculator](#)
[Glossary](#)
[Documentation](#)
[FAQ](#)
[About](#)

Ecosizer inputs:

Building Type

Multifamily

Multifamily

Men's Dorm

Women's Dorm

Hotel/Motel

Elementary School

Junior High

Senior High

Nursing Home

Full-Meal Restaurants and Cafeterias

Drive-Ins, Grills, Luncheonettes, Sandwich, and Snack Shops

Office Building

TOTAL PEOPLE & APARTMENTS **APARTMENT SIZE & OCCUPANCY RATES**

Number of people: Number of apartments: Peak Gallons per Day per Person: (Range: 1 to 49)

Water Temperature

Design Cold: °F Supply: °F Hot Storage: °F

ADVANCED OPTIONS X

Aquastat Fraction: % Drawdown: %

Temperature Maintenance System

SWING TANK

① Primary plant with a temperature maintenance plant in series

PARALLEL LOOP TANK

② Primary plant with a temperature maintenance plant in parallel

PRIMARY - NO RECIRCULATION

③ Just the primary plant without a temperature maintenance load

A temperature maintenance system provides hot water to the taps in a timely manner.

Ecosizer.ecotope.com

50

ECOSIZER

[Size Your System](#)
[TECH-HPWH Calculator](#)
[Glossary](#)
[Documentation](#)
[FAQ](#)
[About](#)

Ecosizer outputs:

Primary System Size, Storage: 553.41 Gal, Capacity: 105.6 kBTU/hr, Compressor Runtime: 16.0 hr

RECOMMENDATIONS
The recommended minimum heating capacity shown below is the **minimum** needed average output capacity of the selected equipment at the design cold air temperature in your climate zone. Note that you must also account for manufacturer specific defrost penalty.

<p>Tank Volume ⓘ 554.00 Gallons</p> <p>Swing Tank Volume ⓘ 50 Gallons</p> <p>CA Title 24 Swing Tank Volume ⓘ 80 Gallons</p>	<p>Heating Capacity ⓘ 105.60 kBTU/hr</p> <p>Swing Resistance Element ⓘ 8.7 kW · 29.9 kBTU/hr</p>
--	---

THIS SYSTEM WAS SIZED FOR

Building Load
100.0 People

Apartments
50 Units

Daily Hot Water Usage
25.0 Gallons per Day per Person

Total Hot Water
2,500.00 Gallons per Day

Recirculation Loop
Heat Loss
100 Watts per Apartment

Ecosizer.ecotope.com

51

Let's check in:

- 1. Questions about sizing?**
- 2. Know of any great DHW usage data?**

52

Time to select a system.

Be your own advocate.

- + Market Delivery Structure
- + Probing Questions
- + Resources



53

Market Delivery Methods



Custom Engineered System

All the pieces are separate and come from multiple distributors and/or manufacturers.



Specified Built-Up System

All the pieces are separate but come from a single distributor or manufacturer.

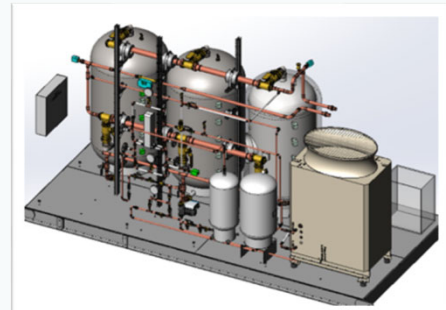

Packaged / Skid

Everything is assembled and delivered in a single package.



54

Market Delivery Methods



Custom Engineered

Designer holds the keys to success. Designer must coordinate thoroughly with product manufacturers and installers to meet overlapping requirements. Highly recommend manufacturer-authorized equipment start-up.



Specified Built-Up

Product rep holds the key to success. Rep must provide a system-level warranty that includes service, start-up, and troubleshooting.

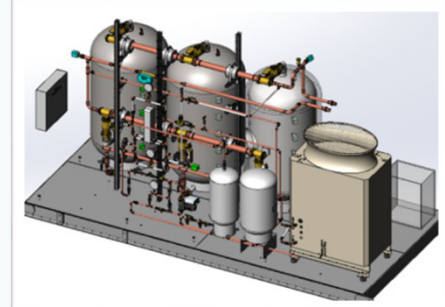

Packaged / Skid

Skid manufacturer holds the keys to success. Manufacturer must provide a system-level warranty that includes service, start-up, and troubleshooting.



55

Probing Questions:

1. Is your HPWH/system on the qualified products list?
2. Are additional items needed to satisfy AWHs requirements?
3. Can you send me the design guidance required by the AWHs?
4. Will this HPWH operate in my hottest and coldest design temperatures without back-up?
5. Which TM configuration do you use and why?
6. Does your warranty cover the full system; parts and labor?
7. Do you provide factory-authorized start-up and DHW plant-level functional testing?
8. How many installs are in my area? Can I see one?



56

Resources

ETO Design Guide

https://www.energytrust.org/wp-content/uploads/2023/04/New-Buildings_Design-Guide-for-Central-Heat-Pump-Water-Heaters.pdf

AWHS Qualified Products List

<https://nea.org/img/documents/commercial-HPWH-qualified-products-list.pdf>

Get to know your manufacturer.

There are no dumb questions!



57

Final Check-in

1. Are you feeling confident?
2. What am I missing?



58

Thank you!

Evan Green
Research and Design
Ecotope
Evan@ecotope.com



59

Class Survey

The survey should only take 2 minutes
and your responses can be confidential.

Here's how to participate:

- Click the provided link
- Or
- Scan the QR code with your phone's camera



60

Class Survey

The survey should only take 2 minutes
and your responses can be confidential.

[Click the provided link to participate](#)



61



THANK YOU



Together, Building
a Better California

PG&E refers to Pacific Gas and Electric Company, a subsidiary of PG&E Corporation. ©2026 Pacific Gas and Electric Company. All rights reserved. These offerings are funded by California utility customers and administered by PG&E under the auspices of the California Public Utilities Commission.

62