



# Manufacturer's Roundtable

Drain Water Heat Recovery Manufacturers Roundtable

June 10, 2026



© New Buildings Institute 2024

## WHAT IS CEDA?



The California Energy Design Assistance (CEDA) program is the only statewide utility incentive program for new construction and major renovations.

- Promotes **electrification** and **decarbonization**
- CEDA works in collaboration with project teams to reduce energy demand, consumption, and carbon emissions.
- Serves commercial, public, high-rise multifamily, industrial, and agricultural projects in Pacific Gas & Electric (PG&E), Southern California Edison (SCE), SoCalGas (SCG), and San Diego Gas & Electric (SDG&E) service areas.



## WHY PARTICIPATE IN CEDA?



- Receive complimentary **decarbonization** analysis tailored to project goals to identify most effective measures to implement



- Gain analysis of **energy costs and paybacks**
- Receive **financial incentives** to help offset the costs of decarbonization measures



- Demonstrate commitment to high performance building practices and design

## INCENTIVES



- **\$4000 Design team incentive** per project as a thank you for participation
- Based on the project measure package the design team chooses for implementation



## HIGH PERFORMANCE MEASURES



CEDA aims to exceed California's decarbonization standards by identifying high performance measures and providing educational opportunities to explore use cases and best practices.

This not only advances the market, but also qualifies participants for enhanced incentives through our program.

A current list of eligible high-performance measures can be found on our website [here](#).



## HAVE A PROJECT TO DISCUSS?



For more information, please contact our program outreach specialists, visit our website, or fill out an interest form

Scan me to enroll a project

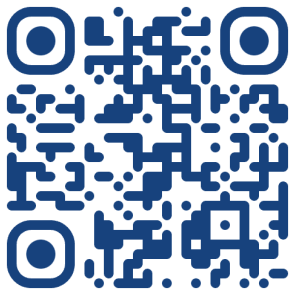

CaliforniaEDA.com

**Tina Hendrix** | Program Outreach Specialist  
[thendrix@willdan.com](mailto:thendrix@willdan.com)  
760.585.7577

---

# Drain Water Heat Recovery

In today's webinar, we'll discuss:

**How DHWR works** and the basic mechanisms of heat recovery

**DWHR configurations** and **products**

Ideal **applications** and **energy savings** potential

Pairing DWHR with **heat pump water heaters**

© New Buildings Institute 2024

---

## Today's Panelists



**Peter Grant**  
LBNL



**Gerald van Decker**  
RenewABILITY



**Marc Fontaine**  
EcolInnovation



**Joe Rendell**  
ORNL

© New Buildings Institute 2024

---

## Panel Question #1

In your opinion, what are the **key variables** that affect DWHR field performance?

Can you recall any **example installation(s)** from the lab or field that over- or under-performed?

---

## Panel Question #2

Are you already seeing DHWR as part of **energy efficiency programs**?

If not, how would you position the technology as part of a wider program?

---

## Panel Question #3

Looking ahead, are there any **innovations** you hope to see in the field?

© New Buildings Institute 2024



# Drain Water Heat Recovery - Technology and Use Cases

**Peter Grant**

## Counterflow Heat Exchanger

Two fluid flows - one hot, one cold

Opposite flow directions

Heat transfers from **hot** fluid to **cold**

Cools hot fluid, warms cool fluid

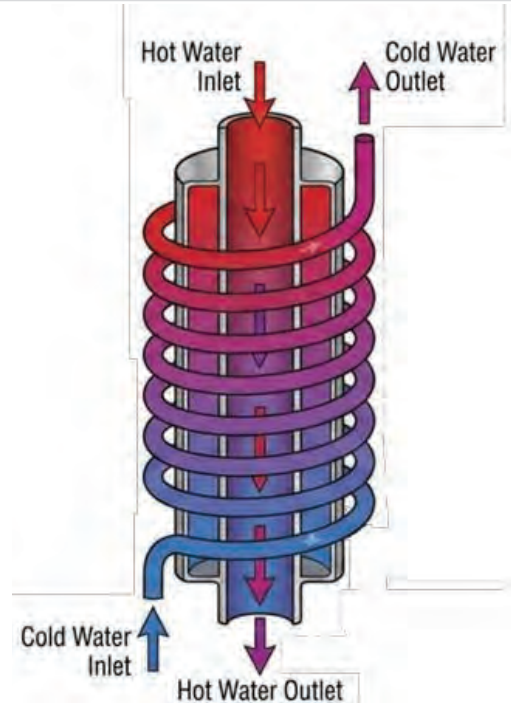

## Building Design Effects

Energy recovered is based on the volume of simultaneous water flow

Large volumes yield more savings

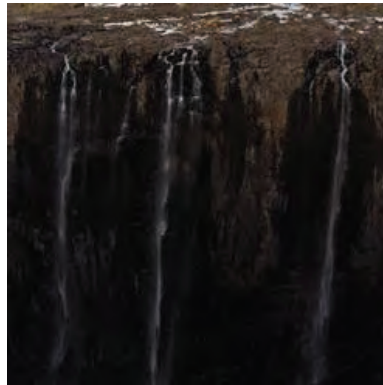

### Low savings

- Low flow fixtures
- Low occupant spaces



### High savings

- High flow fixtures
- Commercial kitchens
- High occupant spaces



## Climate Effects

Energy recovered is based on the difference between the **hot** and cold water temperatures

Colder cold temperatures yield **more savings**

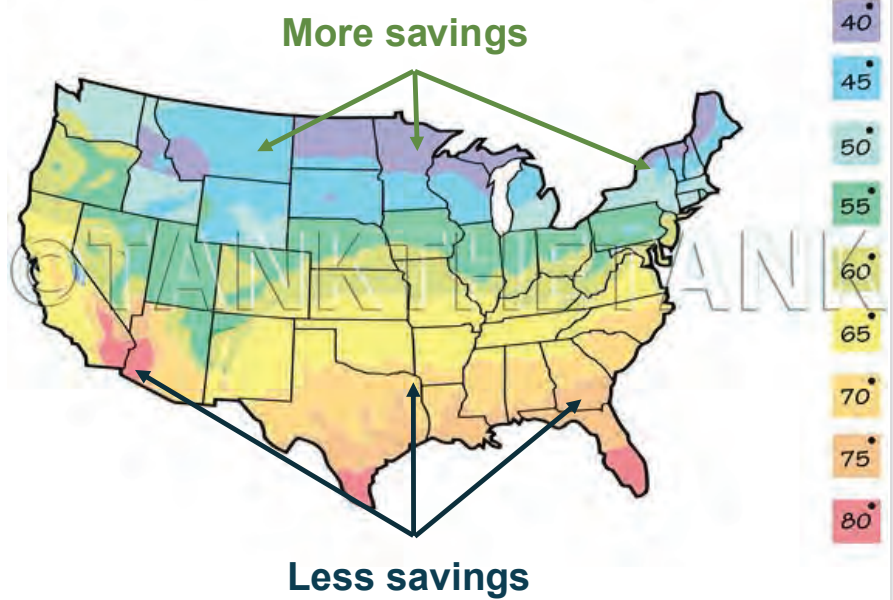

## Vertical Drain Water Heat Recovery



Vertical pipe



Replaces a section of drain pipe



Typically recovers waste heat from shower water



### Installation configurations

**Equal flow:** Preheated water to both shower and water heater

**Unequal-Water Heater:** Preheated water to only water heater

**Unequal-Shower:** Preheated water to only shower

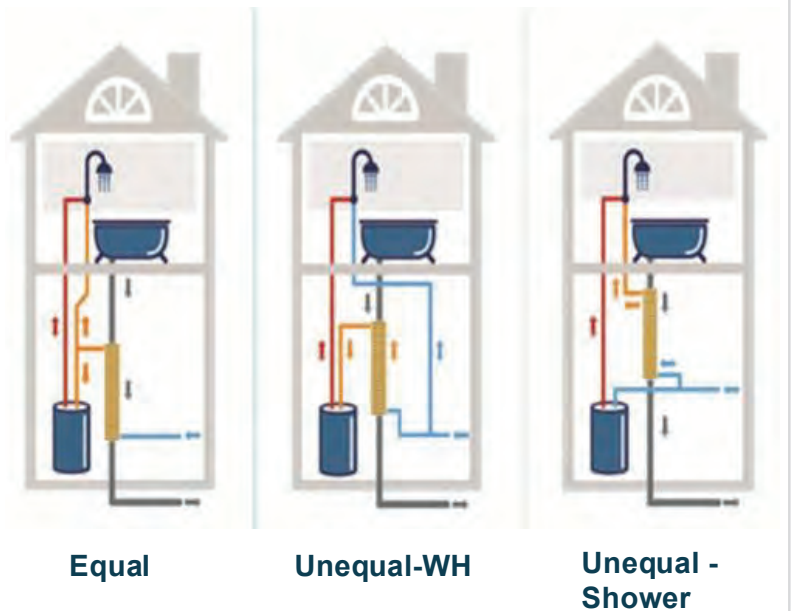

## Horizontal Drain Water Heat Recovery



Horizontal pipe



Replaces a section of horizontal drain pipe



Typically recovers waste heat from shower water



Same installation configurations



Useful where vertical space is not available  
No basement

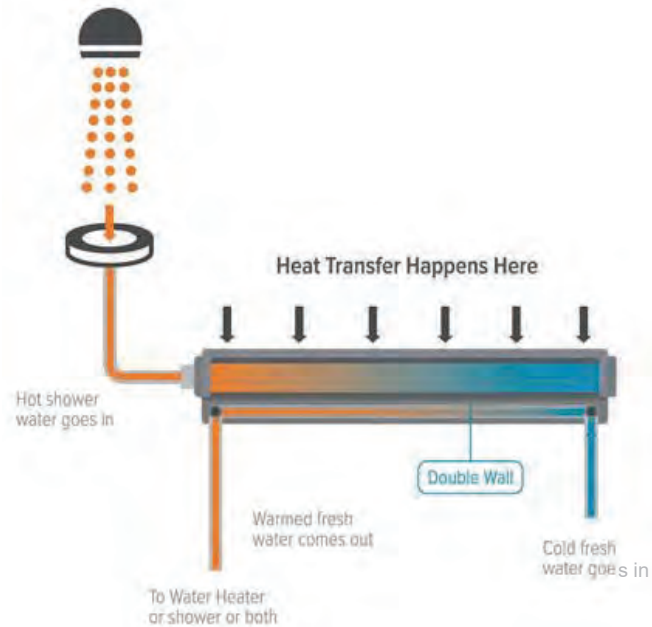

## Heat Recovery Dish Machines



DWHR installed in dishwasher



Used in restaurants



Up to 180 °F water!



Huge hot water loads



## Single Family Residential

- Used to recapture energy from showers
  - ~100 °F when entering drain
- **Ideal:** All showers share a drain
- **Ideal:** Large hot water loads (no low flow showerheads)
- **Vertical:** Target homes with basements
- **Climate:** Best savings in cold climates
  - Cold water temp = savings



## Multifamily Residential & Hotels

- Used to recapture energy from showers
  - ~100 °F when entering drain
- **Shared cost:** Multiple dwellings sharing one DWHR device
  - Local code may require additional metering
- **Ideal:** All showers share a drain
- **Vertical:** Target buildings with basements
- **Climate:** Best savings in cold climates
  - Cold water temp = savings

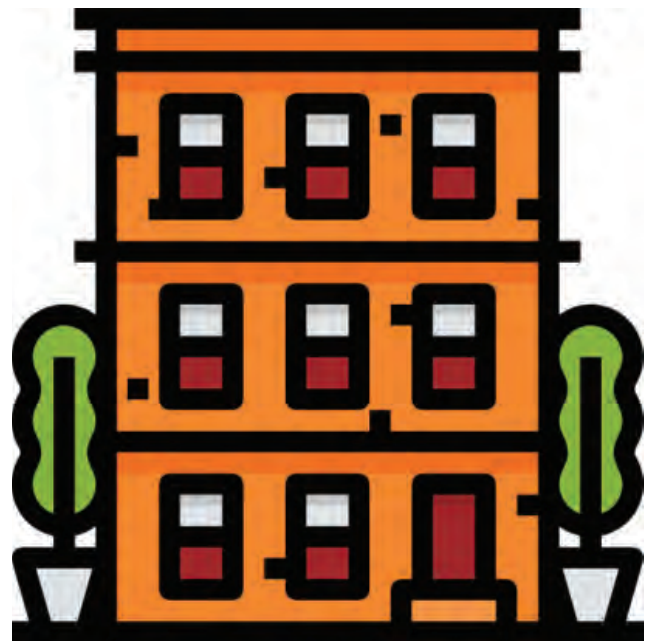

## Other potential uses?



 ENERGY TECHNOLOGIES AREA  
BERKELEY LAB

Image credit: Wikipedia, Conde Nast, NEWD gym

# Thank You

Peter Grant: [pgrant@lbl.gov](mailto:pgrant@lbl.gov)



## Drain Water Heat Recovery (DWHR)

Marc Fontaine P. Eng.

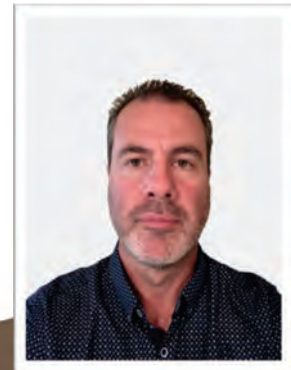

**Ecolnnovation**  
Phone 1.888.881.7853  
Fax 1.888.899.1135  
Website [www.ecolnnovation.ca](http://www.ecolnnovation.ca)



WN 17031 / Certified to CSA B55.1 / Verified to CSA B55.2

**Concept:** DWHR captures heat from wastewater (drain water) to preheat incoming cold water, improving energy efficiency.

### Process:

1. **Wastewater Flow:** Hot water is used in showers or sinks, creating warm wastewater.
2. **Heat Transfer:** As the warm wastewater flows through the heat exchanger, it transfers heat to the cold-water supply line running alongside it.
3. **Preheated Water:** The cold water absorbs heat from the wastewater, becoming warmer before entering the water heater.
4. **Reduced Energy Demand:** The water heater requires less energy to heat the preheated water to the desired temperature.

### How a Drain Water Heat Recovery System works

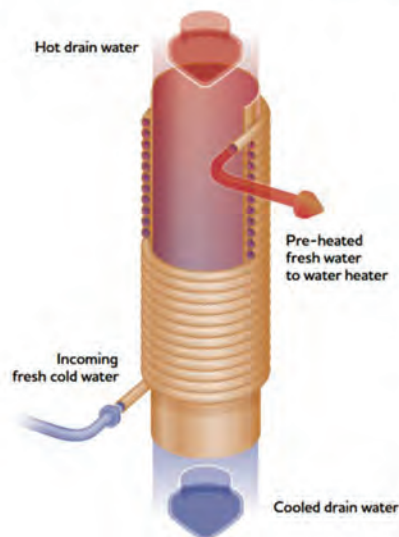

- In a vertical pipe water flows down the walls forming a thin film
- This thin water film on a copper surface transfers heat efficiently to the incoming cold water

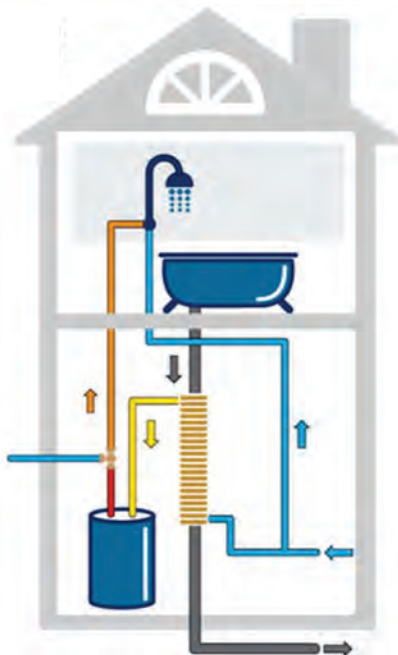
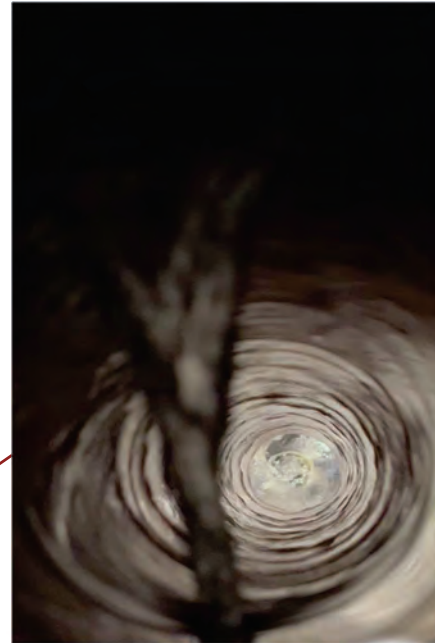

- Working principle
- Simple installation
- Shower is the target fixture
- Other fixtures benefit
- All fixtures including toilet = OK
- Large homes can have 2 DWHR units, layout

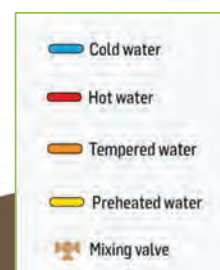

- Shower example:
  - 42% efficiency

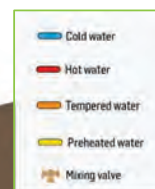
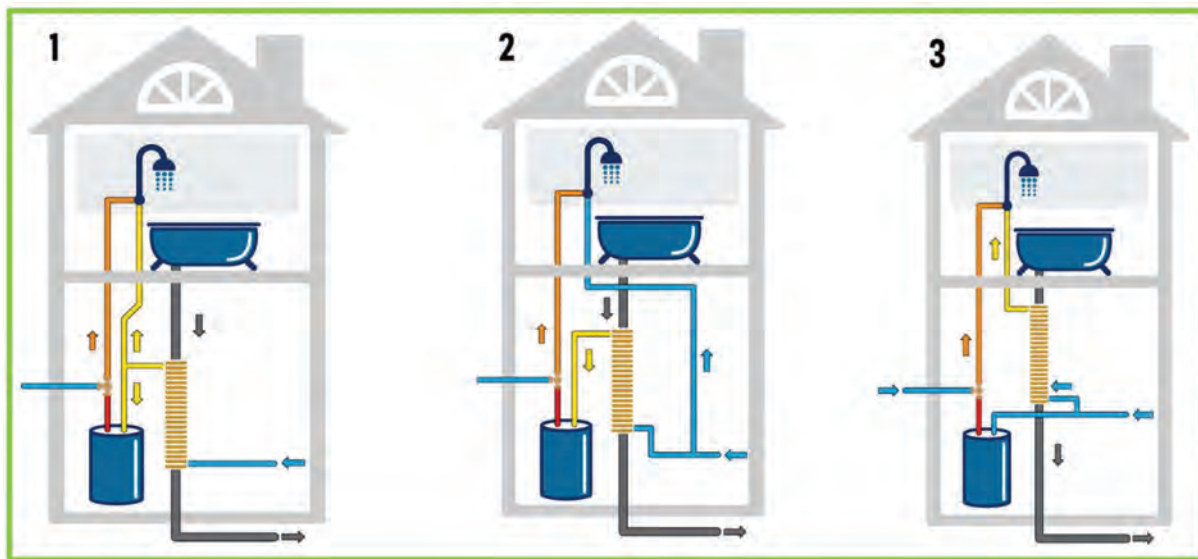
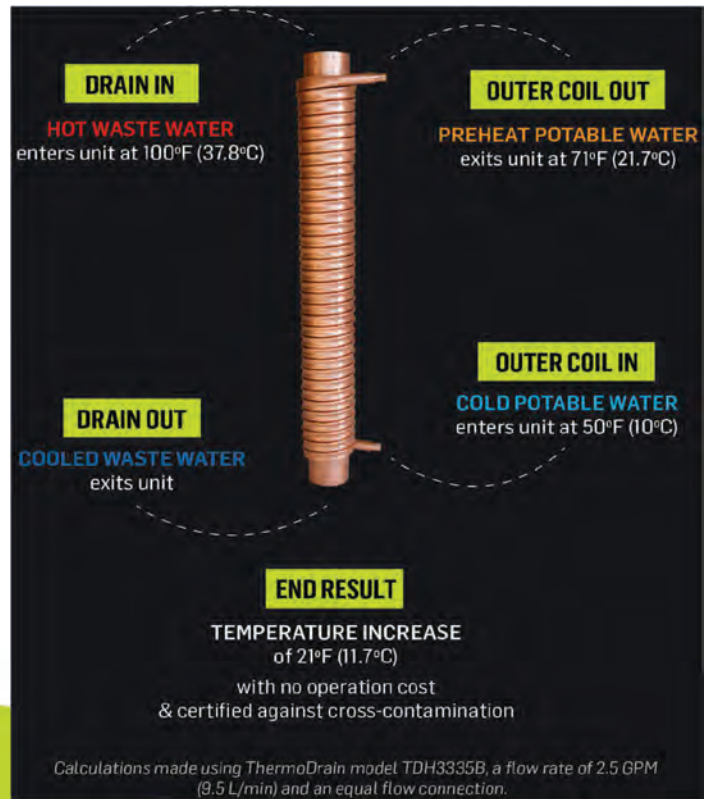

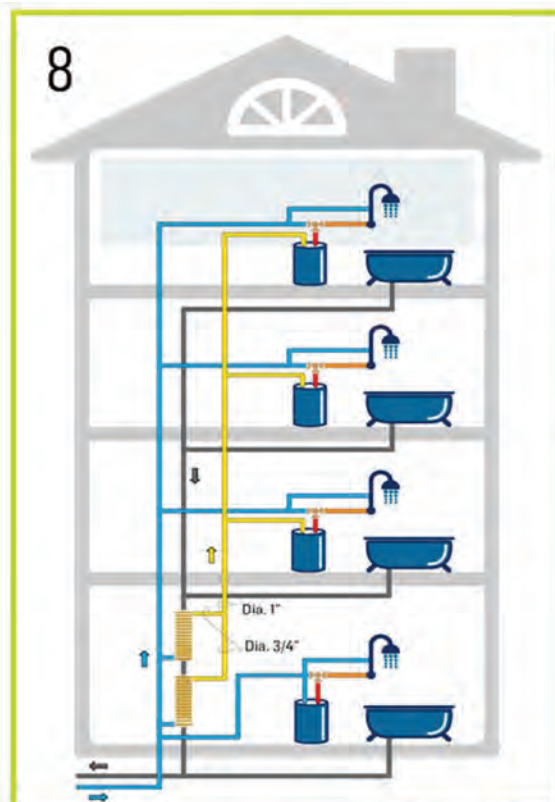
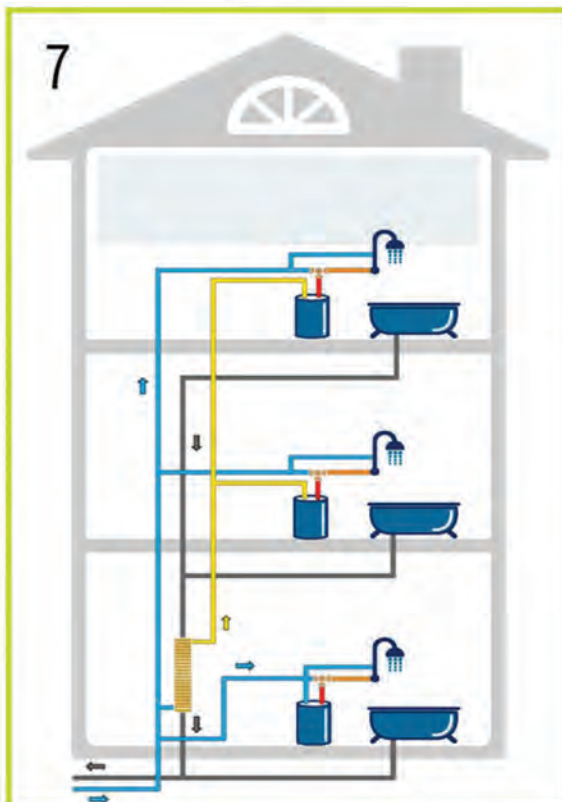
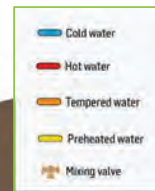
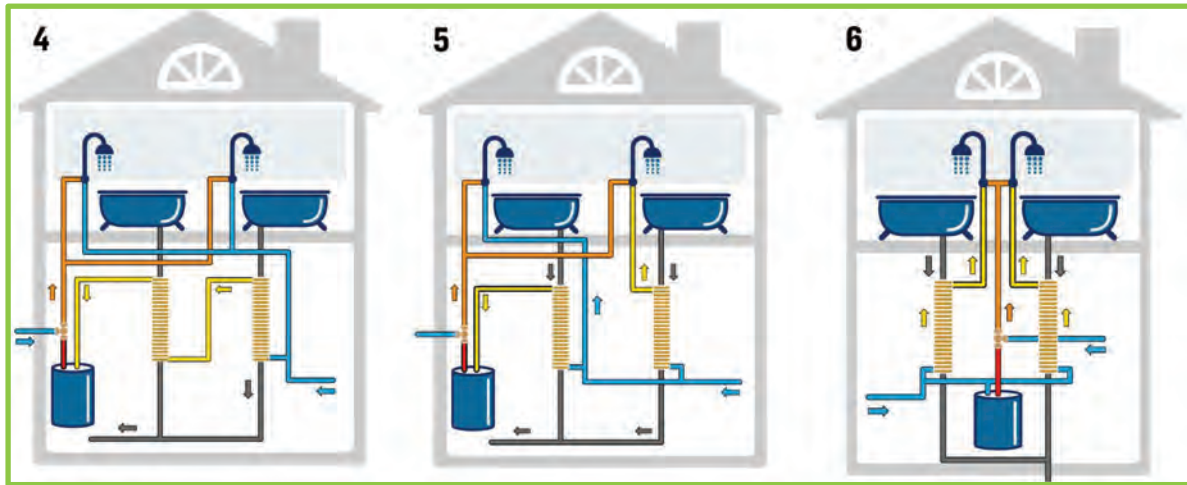

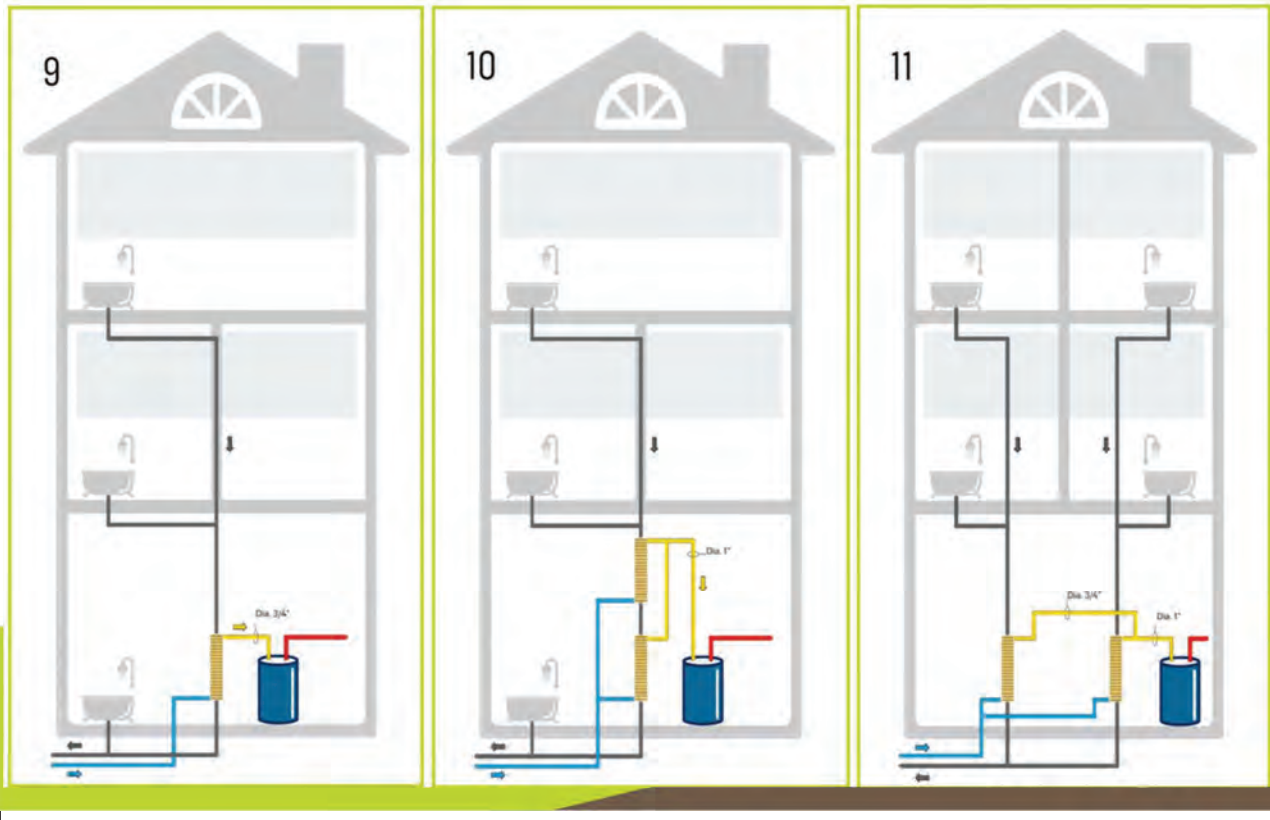

### 6-Plex case study

Using EnerGuide guidelines for showers of 1.13h/week/dwelling with a 2-person occupancy, 7.6L/min shower head, a DWHR system at 46% efficiency will save 695 kWh/year/dwelling.

Translating to 2780 kWh/year when considering 4 of 6 dwellings or **6.2%** reduction in energy use in our model.





### Cold water connection

- 3/4" nominal
- Copper, PEX, Expansion PEX

### Drain connection

- Mechanical coupling
- 3" or 4"

### Multiple Stacked Units

- Combine units for increased flow rates



MODEL	LENGTH (in)	EFFICIENCY (%) at 9.5L/min (2.5 GPM)	PRESSURE LOSS (psi) at 9.5L/min (2.5 GPM)	HEAT RECOVERY (kW)	MASS (lbs)	MODEL	LENGTH (in)	EFFICIENCY (%) at 9.5L/min (2.5 GPM)	PRESSURE LOSS (psi) at 9.5L/min (2.5 GPM)	HEAT RECOVERY (kW)	MASS (lbs)
TDH3320B	32.0	41.0	2.0	7.7	15.4	TDH3475B	47.5	50.8	2.3	9.6	24.4
TDH3325B	32.5	41.4	2.0	7.8	15.7	TDH3480B	48.0	51.0	2.3	9.6	24.7
TDH3330B	33.0	41.8	2.0	7.9	16.0	TDH3485B	48.5	51.3	2.3	9.7	25.0
TDH3335B	33.5	42.1	2.1	7.9	16.3	TDH3490B	49.0	51.6	2.4	9.7	25.3
TDH3340B	34.0	42.5	2.1	8.0	16.6	TDH3495B	49.5	51.8	2.4	9.8	25.5
TDH3345B	34.5	42.8	2.1	8.1	16.9	TDH3500B	50.0	52.1	2.4	9.8	25.8
TDH3350B	35.0	43.2	2.1	8.1	17.2	TDH3505B	50.5	52.3	2.4	9.8	26.1
TDH3355B	35.5	43.5	2.1	8.2	17.5	TDH3510B	51.0	52.6	2.4	9.9	26.4
TDH3360B	36.0	43.8	2.2	8.3	17.8	TDH3515B	51.5	52.8	2.4	9.9	26.7
TDH3365B	36.5	44.2	2.1	8.3	18.1	TDH3520B	52.0	53.0	2.4	10.0	26.9
TDH3370B	37.0	44.5	2.1	8.4	18.4	TDH3525B	52.5	53.3	2.4	10.0	27.2
TDH3375B	37.5	44.8	2.2	8.5	18.7	TDH3530B	53.0	53.5	2.4	10.1	27.5
TDH3380B	38.0	45.2	2.2	8.5	18.9	TDH3535B	53.5	53.7	2.4	10.1	27.8
TDH3385B	38.5	45.5	2.2	8.6	19.2	TDH3540B	54.0	54.0	2.4	10.1	28.1
TDH3390B	39.0	45.8	2.2	8.6	19.5	TDH3545B	54.5	54.2	2.4	10.2	28.3
TDH3395B	39.5	46.1	2.2	8.7	19.8	TDH3550B	55.0	54.4	2.4	10.2	28.6
TDH3400B	40.0	46.4	2.2	8.8	20.1	TDH3555B	55.5	54.6	2.4	10.2	28.9
TDH3405B	40.5	46.8	2.2	8.8	20.4	TDH3560B	56.0	54.8	2.4	10.3	29.2
TDH3410B	41.0	47.1	2.2	8.9	20.7	TDH3565B	56.5	55.1	2.4	10.3	29.4
TDH3415B	41.5	47.4	2.2	8.9	21.0	TDH3570B	57.0	55.3	2.4	10.4	29.7
TDH3420B	42.0	47.7	2.2	9.0	21.3	TDH3575B	57.5	55.5	2.4	10.4	30.0
TDH3425B	42.5	48.0	2.3	9.0	21.6	TDH3580B	58.0	55.7	2.4	10.4	30.3
TDH3430B	43.0	48.3	2.3	9.1	21.8	TDH3585B	58.5	55.9	2.4	10.5	30.5
TDH3435B	43.5	48.6	2.3	9.2	22.1	TDH3590B	59.0	56.1	2.4	10.5	30.8
TDH3440B	44.0	48.8	2.3	9.2	22.4	TDH3595B	59.5	56.3	2.4	10.5	31.1
TDH3445B	44.5	49.1	2.3	9.3	22.7	TDH3600B	60.0	56.4	2.4	10.6	31.4
TDH3450B	45.0	49.4	2.3	9.4	23.0	TDH3605B	60.5	56.6	2.4	10.6	31.6
TDH3455B	45.5	49.7	2.3	9.4	23.3	TDH3610B	61.0	56.8	2.4	10.6	31.9
TDH3460B	46.0	50.0	2.3	9.5	23.6	TDH3615B	61.5	57.0	2.4	10.6	32.2
TDH3465B	46.5	50.2	2.3	9.5	23.8	TDH3620B	62.0	57.2	2.5	10.7	32.4
TDH3470B	47.0	50.5	2.3	9.5	24.1						

Note: All models have a 3" drain diameter





WN 17031  
Verified CSA B55.1 1-15  
Certified CSA B55.2 2-15

The CSA B55.1 standard is for measuring efficiency and pressure loss of drain water heat recovery units

The CSA B55.2 This Standard specifies health and safety requirements for drain water heat recovery (DWHR) units. This Standard was developed in response to the need for a document that specifies safety and performance criteria for DWHR units.



Look for DWHR under the Domestic Hot Water tab

Look for DWHR under the DHW EFFICIENCIES tab

Look for DWHR under the WATER tab

- DWHR can provide 1-2 points reduction of HERS rating
- Use lowest Efficiency to obtain the result, 41 % good start point
- Great value proposition points per \$
- Should be considered a base efficiency measure



Technical Support and Engineering

**Marc Fontaine**

Email: [mfontaine@ecoinnovation.ca](mailto:mfontaine@ecoinnovation.ca)

Cell: 1 514 261 5268

Sales and Distribution Support

**Carolyn Mailloux**

Email: [carolyn@ecoinnovation.ca](mailto:carolyn@ecoinnovation.ca)

Cell: 1 438 221 1443

Contact:  
Marc Fontaine Eng.  
514-261-6258  
[mfontaine@ecoinnovation.ca](mailto:mfontaine@ecoinnovation.ca)  
Web: [Thermodrain.ca](http://Thermodrain.ca)



June 11, 2026 | CEDA

# Drain Source HPWH and HVAC

Joseph Rendall

ORNL

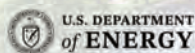

ORNL IS MANAGED BY UT-BATTELLE LLC  
FOR THE US DEPARTMENT OF ENERGY

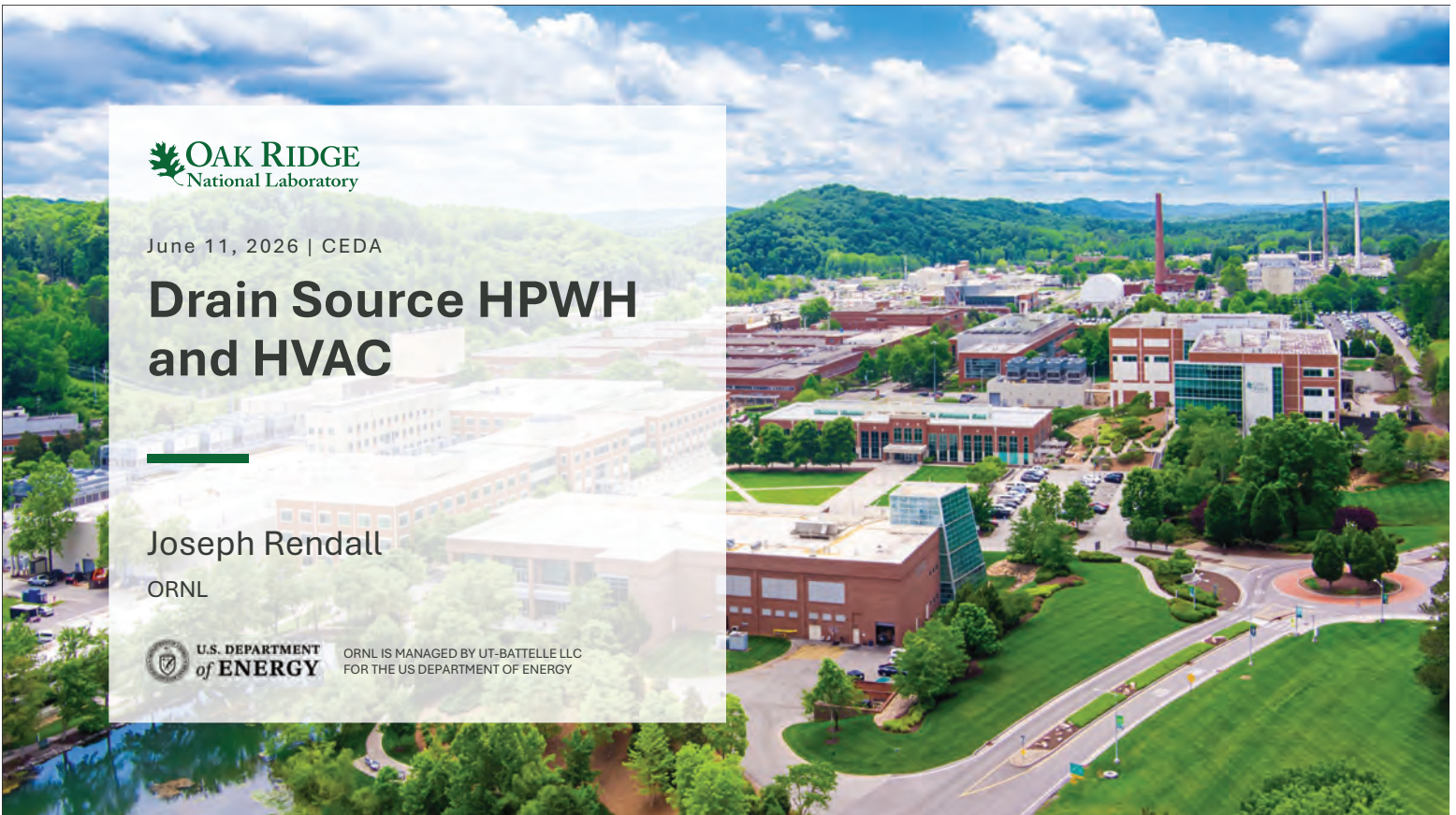

# Outline

Why drain water heat recovery with high performance water heaters?

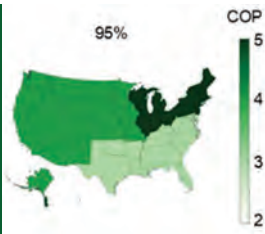

System design comparison for resilience and lowest cost operation

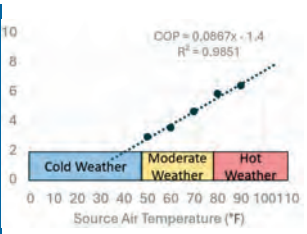

Experimental testbed and Model at ORNL

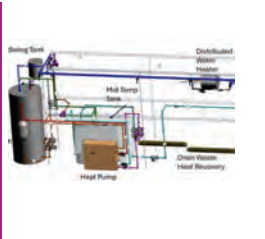

Projected savings based on system designs (example)

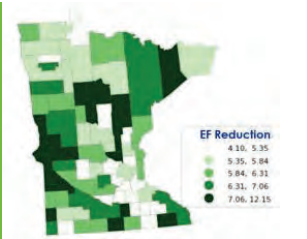

## Prices vary regionally, but nation wide a high COP is needed to be cost effective against high performance natural gas heating

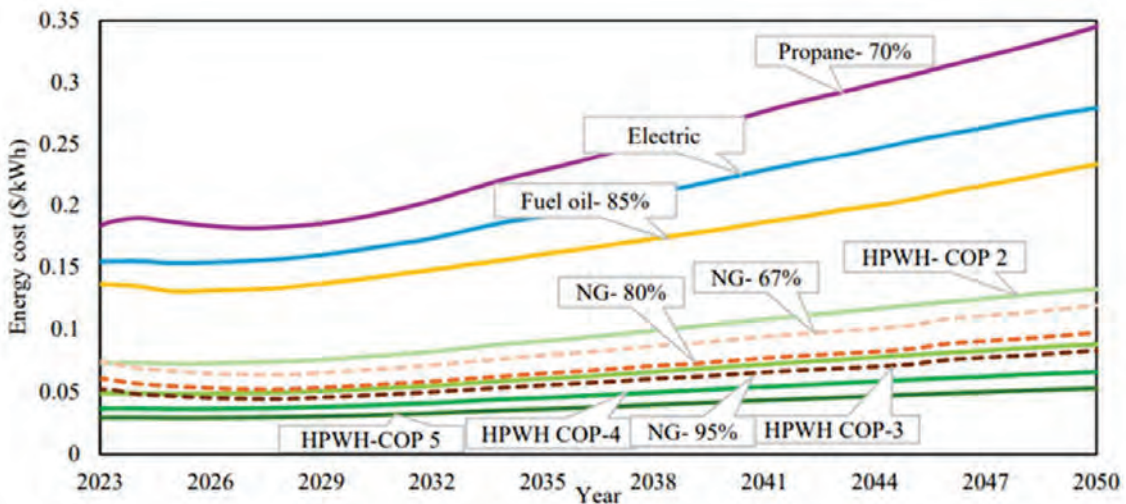

Malhotra, M., Krishnan, E., Rendall J., Casey, F., “Cost reduction of heat pump water heating in cold climates for low to moderate income families” 8th International High Performance Buildings Conference, West Lafayette, IN, July 2024

# Regionally, against different level efficiency natural gas water heating these are the COPs needed to be cost effective.

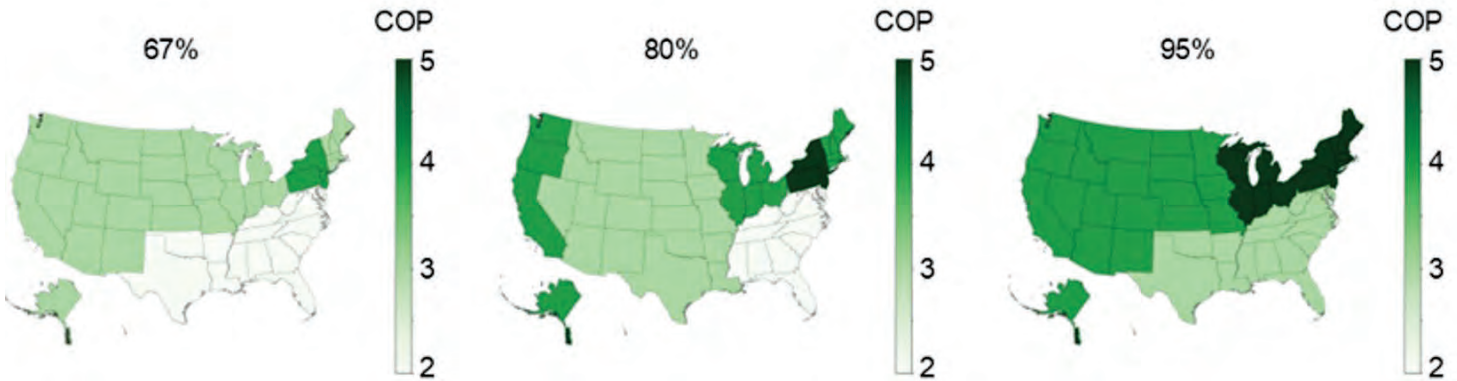

Malhotra, M., Krishnan, E., Rendall J., Casey, F., “Cost reduction of heat pump water heating in cold climates for low to moderate income families” 8th International High Performance Buildings Conference, West Lafayette, IN, July 2024

# Drain heat recovery adds about 20%-30% of energy required for heating back onto the evaporator side of the HP.

Air Source Heat Pump Water Heater Schematic

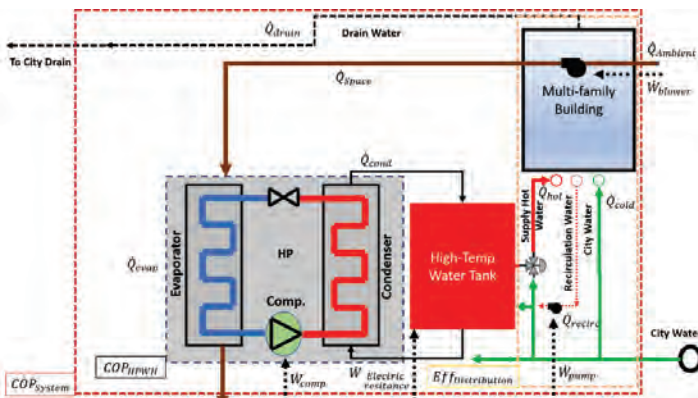

Drain Source Heat Pump Water Heater Schematic

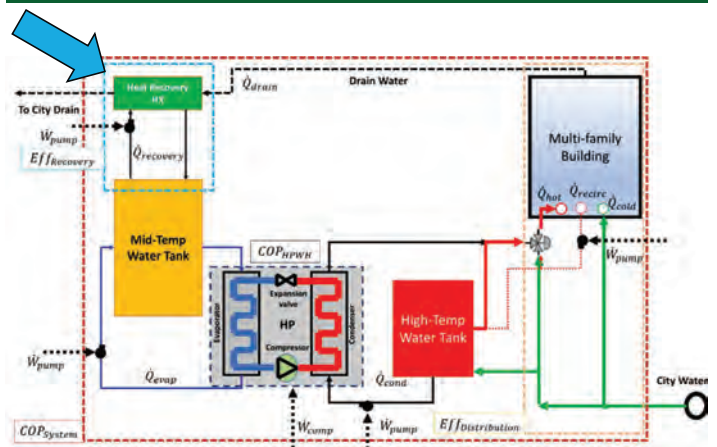

Rendall, J., Nawaz, K., An, K., Malhotra, M., Casey, F., Worek, W., Li, Y., Sun, J., Elatar, A., Rooney, T., Klein, G., Brechtel, J., “Heat pump water heating for multifamily buildings in cold climates to reduce the energy burden for residents with low to moderate incomes,” ASHRAE 2024 Winter Conference, Chicago, IL, January, 2024

# Year-round performance can be guaranteed with a drain source HPWH

## Air Source Heat Pump Water Heater

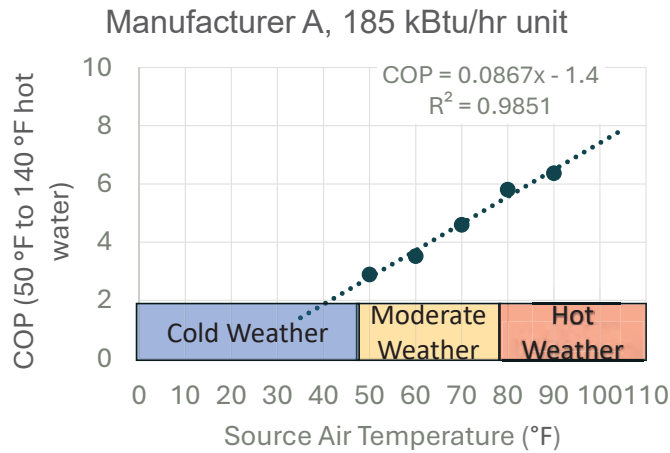

## Drain Source Heat Pump Water Heater

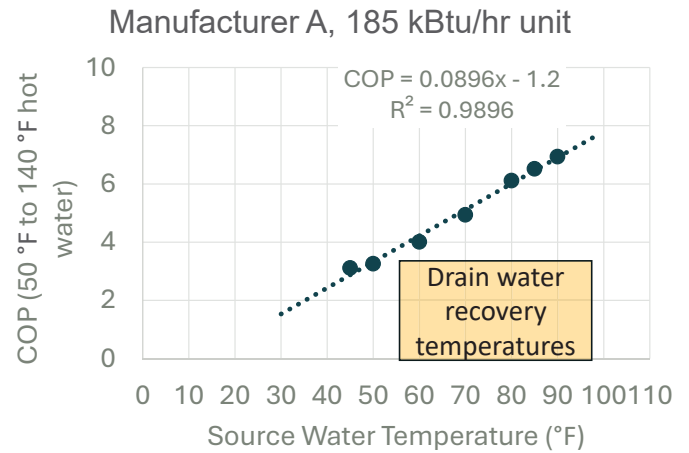

# Drain water heat recovery savings increase with water heating (level 3) and with hydronic space cooling/heating (level 4)

## Level 3 – DWHR + HPWH

## Level 4 - DWHR + HP + Space Cooling/Heating

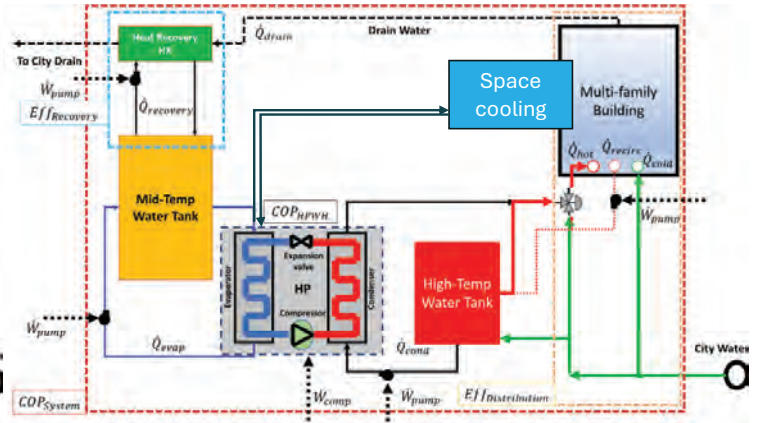
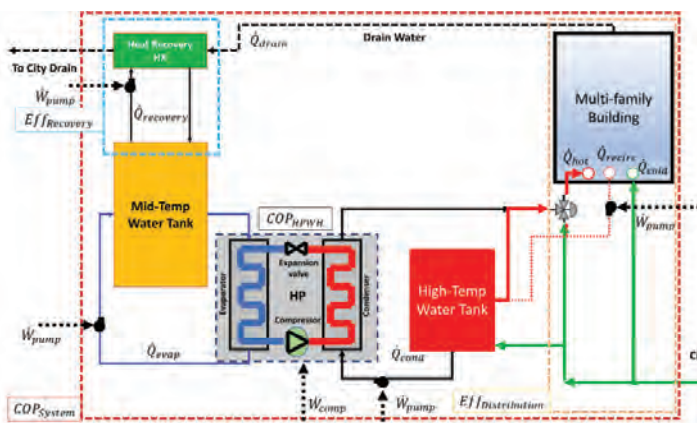

Cost compression of heat pump water heaters for multifamily housing in cold climates April 2023, *DOE PEER Review 2023*, Arlington, VI

# Experimental setup for simulating drain temperature in 35-unit apartment complex

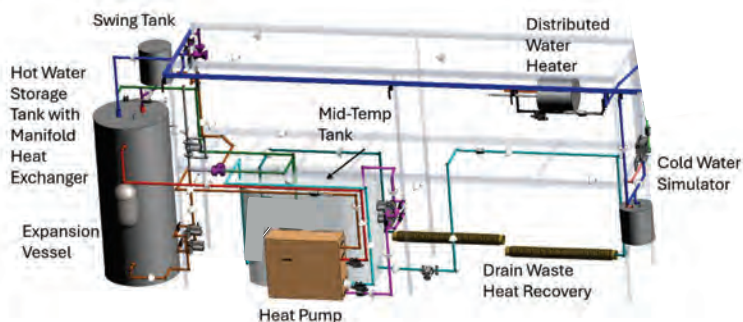

Hot water and return piping

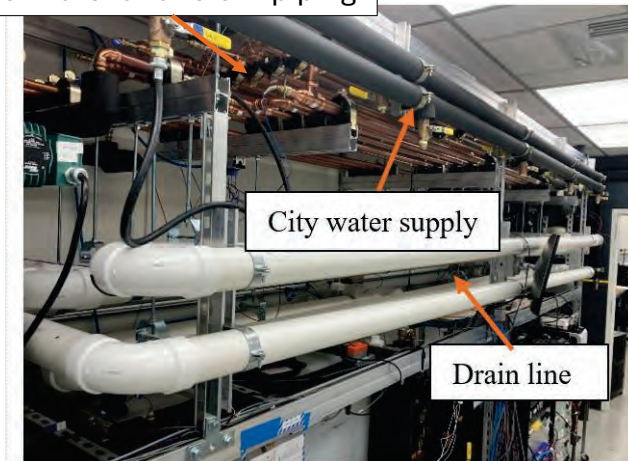

Experimental Demonstration of Drain Source High Performance Water Heaters, Joe Rendall, Easwaran Krishnan, James Manley, Jamieson Brechtle, Kashif Nawaz *manuscript under review (Refrigeration and Air Conditioner Conference – 2026 Herrick Conferences)*

# Model output Minnesota (example)

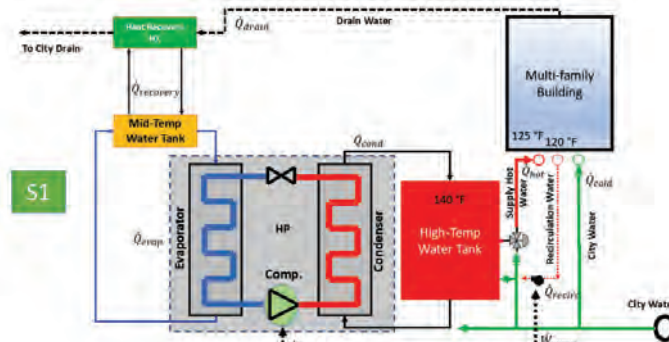
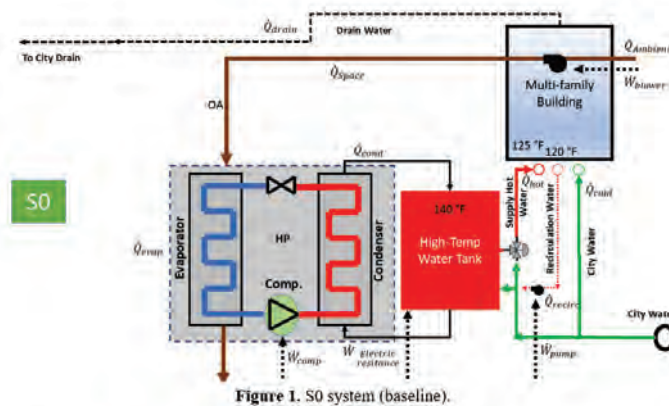
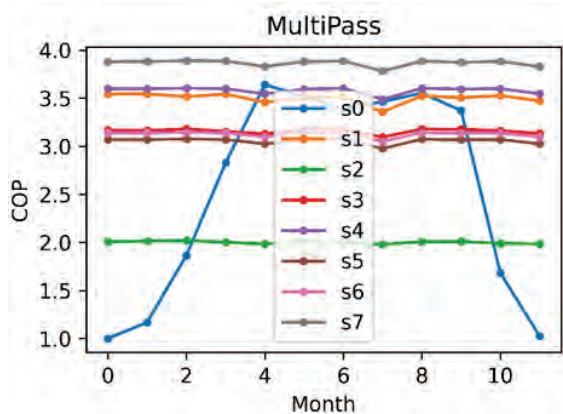

# Drain water heat recovery savings increase with water heating (level 3) and with hydronic space cooling/heating (level 4)

## Level 3 – DWHR + HPWH

Unitary - Electric Resistance Water Heating

Energy affordability (Baseline)

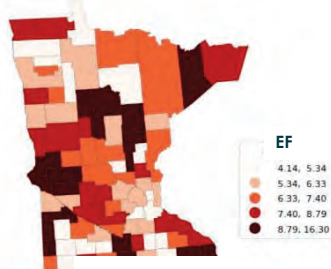

Central – Drain Source Water Heating

Energy affordability reduction due to DS-HPWH

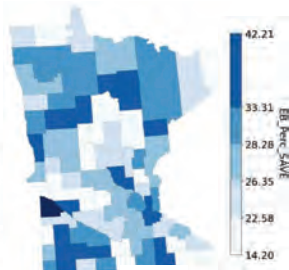

Significant energy affordability reduction estimated (14% to 42%)

## Level 4 - DWHR + HP + Space Cooling/Heating

Unitary - Electric Resistance Space and Water Heating, Electric Cooling

Energy affordability (Baseline)

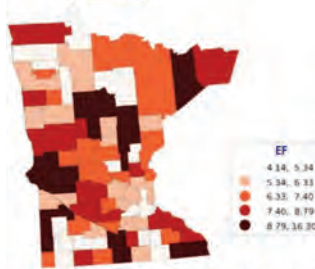

Central - Drain and Dual Source Space Heating, Cooling and Water Heating

Energy affordability reduction due to adopt D-DS HVAC

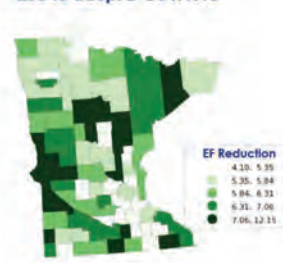

Significant energy affordability reduction estimated (> 50%)

Cost compression of heat pump water heaters for multifamily housing in cold climates April 2023, *DOE PEER Review 2023*, Arlington, VI



Questions and comments please

Contact

Email: [Rendljd@ornl.gov](mailto:Rendljd@ornl.gov)

Phone: 865-341-0422

# Drain Water Heat Recovery Energy: Technology and Applications



500 Trillium Drive - Unit #21  
Kitchener, Ontario, Canada  
N2R 1E5

Tel: (519)885-0283

[www.RenewABILITY.com](http://www.RenewABILITY.com)

By: Gerald Van Decker, M.A.Sc., P.Eng.  
gerald@renewability.com

## Drain Water Heat Recovery (DWHR)

DWHR (usually) works by  
using the outgoing  
warm drain water  
to pre-heat the incoming  
cold fresh water



Fresh Inlet ~ 46°F

Drain Inlet ~ 101°F

Fresh Outlet ~ 75°F



## The Energy Resource.....

- Heat energy in Drain Water in many building types is often a huge untapped resource
- This heat energy can be safely and cost effectively recovered with Drain Water Heat Recovery (**DWHR**)
- Key benefit of DWHR - the energy saved by reducing the primary water heating energy load
- **DWHR savings is proportional to:**  
**Hot Water Load and DWHR Unit Efficiency**

## “Energy Flow” Example - Without DWHR

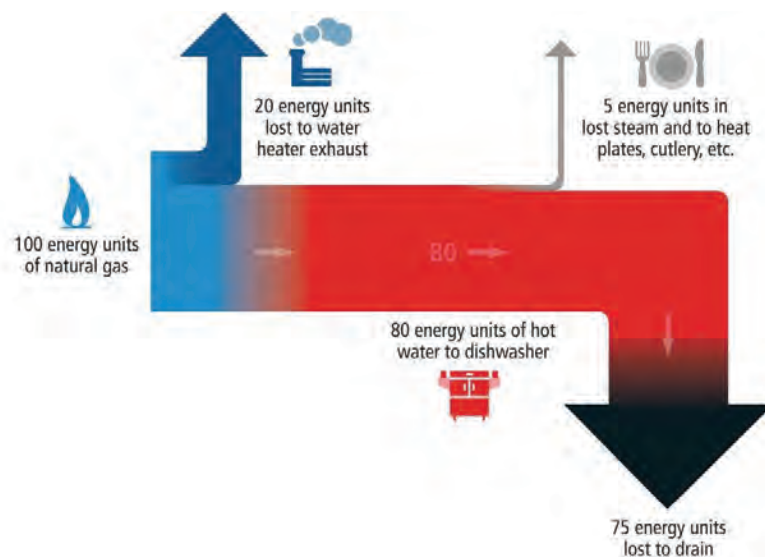

## “Energy Flow” Example - With DWHR

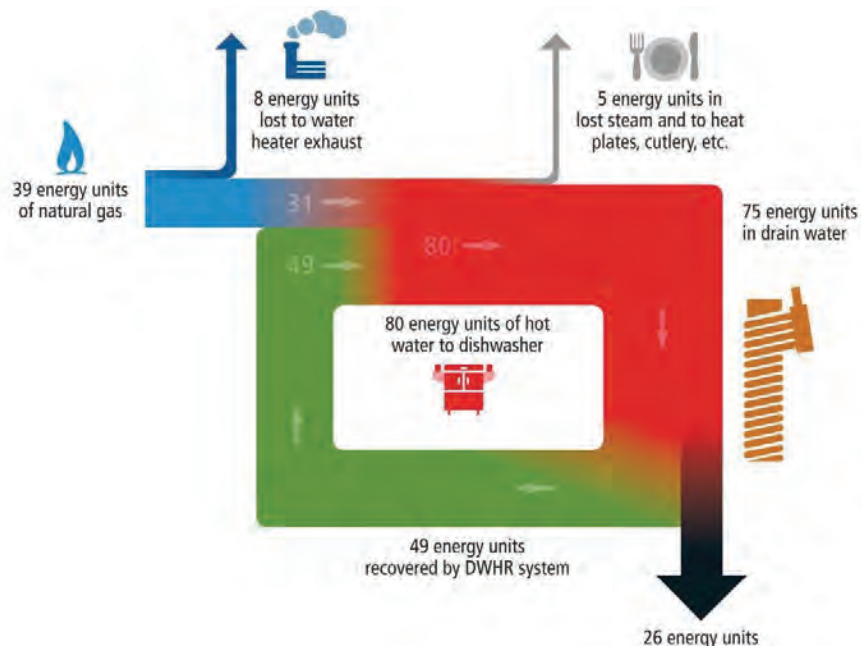

## CSA Standards for DWHR

Required by Building Codes across North America



B55.1-12



B55.2-12

Test method for measuring efficiency and pressure loss of drain water heat recovery units



Performance Standard

Drain water heat recovery units



Safety Standard

## Check the Label

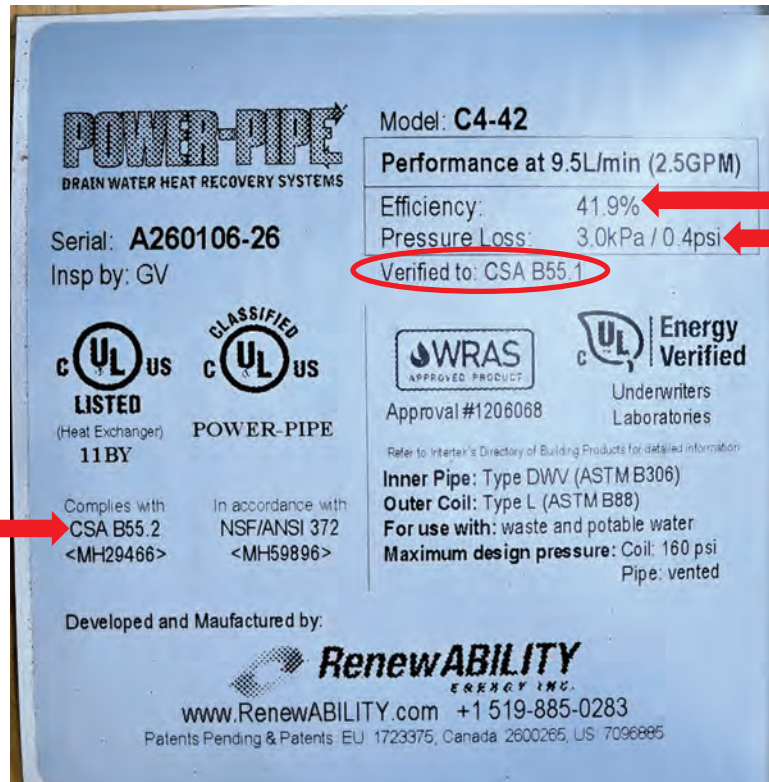

Must comply to CSA B55.2

Efficiency (Effectiveness)

Best to be < 2psi to maintain good flow/pressure in the home

## Falling-Film Heat Exchangers

- Center Section:
  - Open pipe
  - Large solids can pass easily
- Surface Tension:
  - As water falls down a vertical drain pipe, it clings to the inner surface
- Drain Water:
  - A very thin, turbulent film
  - < 1 mm thick

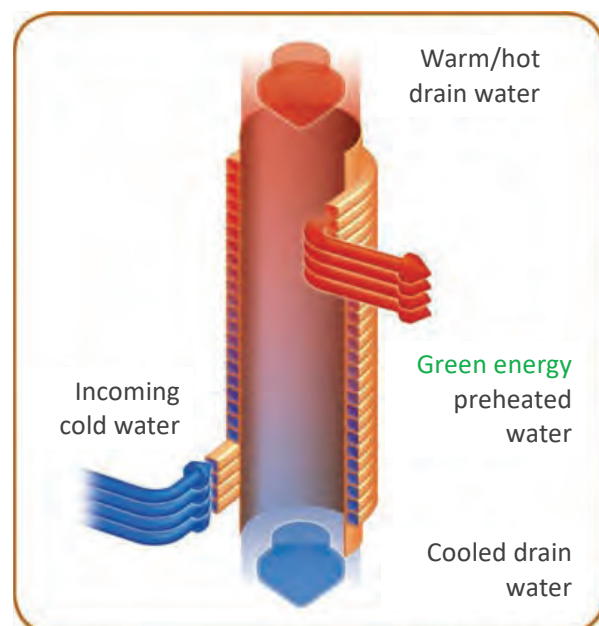



## Falling-Film Heat Exchangers (cont.)

Drain Water

Heat Transfers to

Fresh Water

- Heat transfer:
  -  Contact time is not essential
  -  Intimate contact between fluids and walls separating them is key
- All falling-film DWHR units are:
  - Non-fouling
  - Maintenance-free
- Most falling-film DWHR units are:
  - Efficient
  - Practical

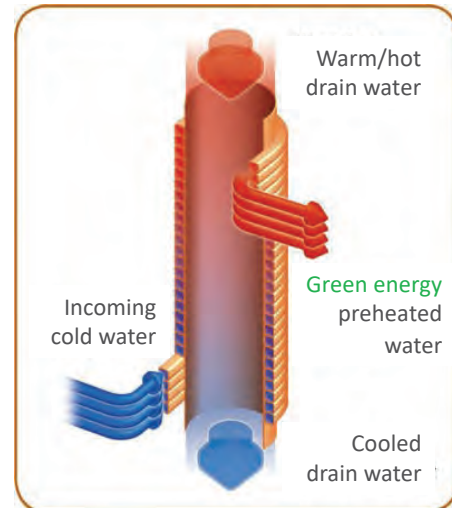

## DWHR – Technology Design Considerations

### 1- Potable Water Safety

- Double-walled and vented
- Two walls of separation  
dirty drain water // fresh potable water

### 2- Water Pressure Loss

- Pressure loss is necessary but it must be minimized so that it does not affect water flow

### 3+ Counter-Flow

- Necessary for high efficiency

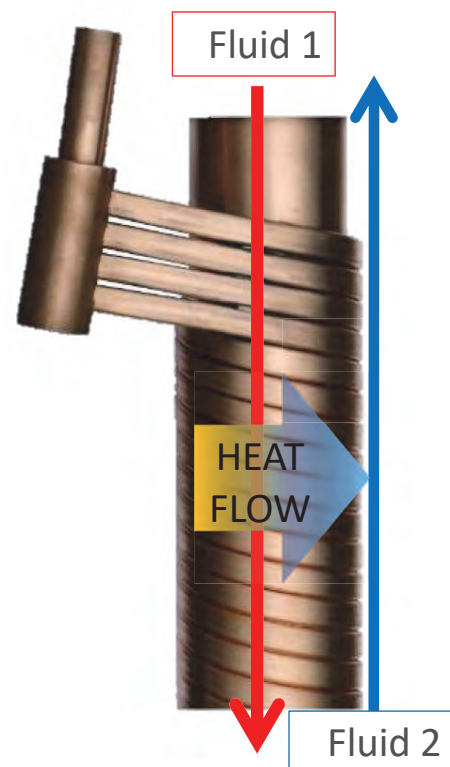

## DWHR – Technology Design Considerations

### 4- Efficient and Low Maintenance

- Excellent contact between the two walls
- Long service life
- Maintenance-free
- Does not foul over time

### 5- Variety of Sizes

Freshwater connection:  
½in, ¾in, 1in, 1-½in

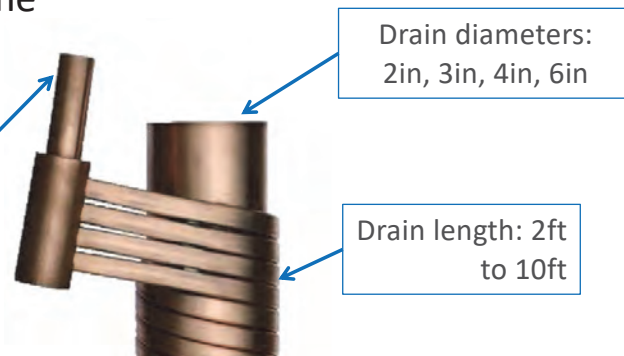

- Option: Multi-pipe DWHR systems

## Single Horizontal Units: YES, they are coming!

- -The CSA B55.1 Performance Standard was updated in 2020 for Horizontal Efficiency Testing and Labelling
- -(Near) Horizontal Ratings for single homes are coming out soon
- -Central Horizontal Systems are being installed in Multi-Family Residential



CSA B55.1:20  
National Standard of Canada



Test method for measuring efficiency and pressure loss of drain water heat recovery units



Standards Council of Canada  
Conseil canadien des normes

**Figure A.2**  
DWHR example test apparatus schematic — Horizontal application  
(See Clause 3.1.)

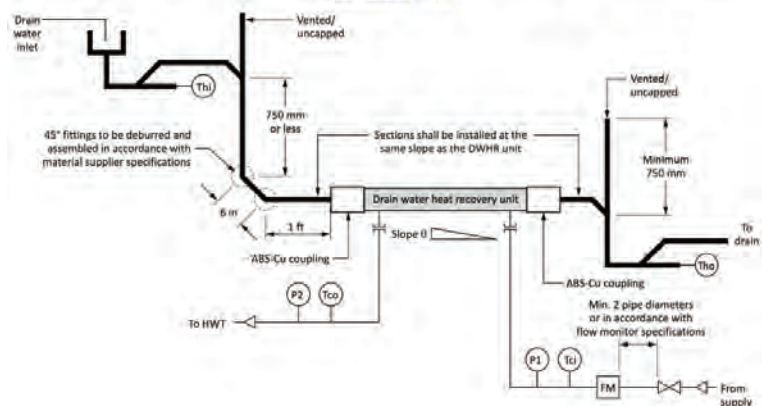



## Installation: Equal Flow – Most Energy Savings

- connect fresh water from DWHR unit to the cold side of shower and to the water heater (all the water in the home, except the kitchen sink)

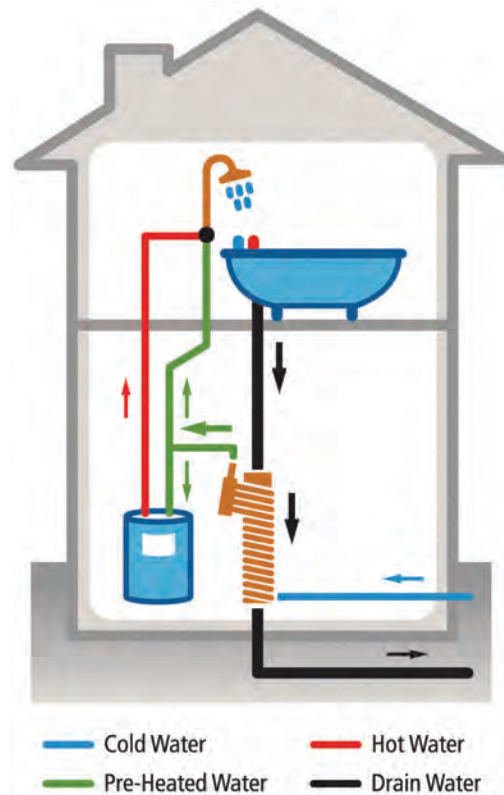

## Installation: Unequal Flow to the Cold Side of Shower

- Connect preheated water connected to the cold side of shower only
- also results in about 23% lower energy savings than equal flow

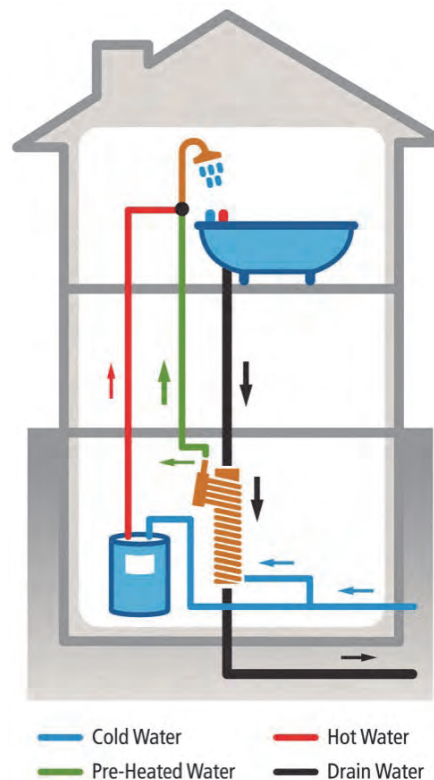

## Installation: Very Simple

### POWER-PIPE Drain Water Heat Recovery Systems INSTALLATION GUIDE



**1. MEASURE**

- Measure and mark "4" up from the bottom of the drainpipe for **BOTTOM CUT** marking.
- Starting from the **BOTTOM CUT** marking, measure the length of the Power-Pipe unit up the drainpipe and mark a line. This will be the **TOP CUT** marking.

**2. CUT**

- At the **BOTTOM CUT** and **TOP CUT** markings cut and remove the drainpipe section.

**3. DE-BURR**

- De-bur drainpipe openings.

**4. CONNECT COUPLINGS**

- Wet inside of couplings and slide larger side of each coupling onto drain pipe openings.
- Push Power-Pipe unit up into top coupling.

**5. TIGHTEN**

- Move bottom coupling up onto the bottom of the Power-Pipe unit and tighten all clamps.

**6. CONNECT INCOMING COLD WATER**

- Divert main cold water supply after water meter (or after water softener) to **BOTTOM** of Power-Pipe coil header.

**7. CONNECT OUTGOING PRE-HEATED WATER**

- Connect **OUTGOING** heated water from **TOP** of Power-Pipe coil header to all cold water fixtures in house and water heater.
- Check and tighten all connections.

**ELEMENTS INCLUDED**

- Two Steel Banded Couplings

Power-Pipe

For more information contact the manufacturer:  
RenewABILITY Energy Inc.  
Tel: 519 885-0283 • Toll free: 1 877 606-5559  
[renewability.com](http://renewability.com)

\*NOTE: This is known as EQUAL FLOW configuration which provides maximum energy savings and reduces sweating on the cold water lines. It is typically the easiest installation method resulting in the cold water leaving at room temperature when a shower is in operation.

Developed and manufactured by  
**RenewABILITY**  
ENERGY INC.

## Multi-Residential with Central Hot Water

-Temper cold water for up to 6 Washrooms per Power-Pipe

-New Construction for all buildings and often Retrofit in Low-Rise

-Temper cold water for up to 6 Washrooms per Power-Pipe

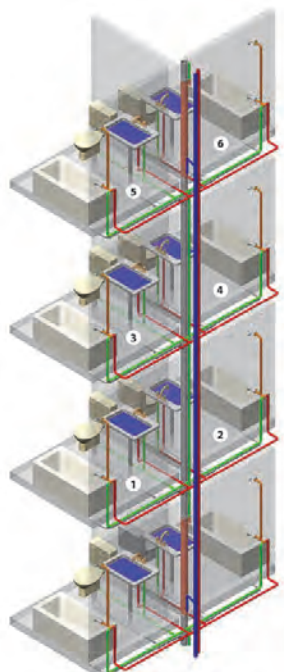

6 WC arranged 2 by 3

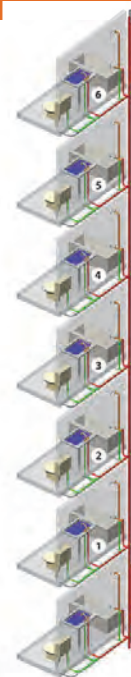

6 WC arranged 1by6

6 WC arranged 1 by 6

## Multi-Residential with In-Suite Water Heaters

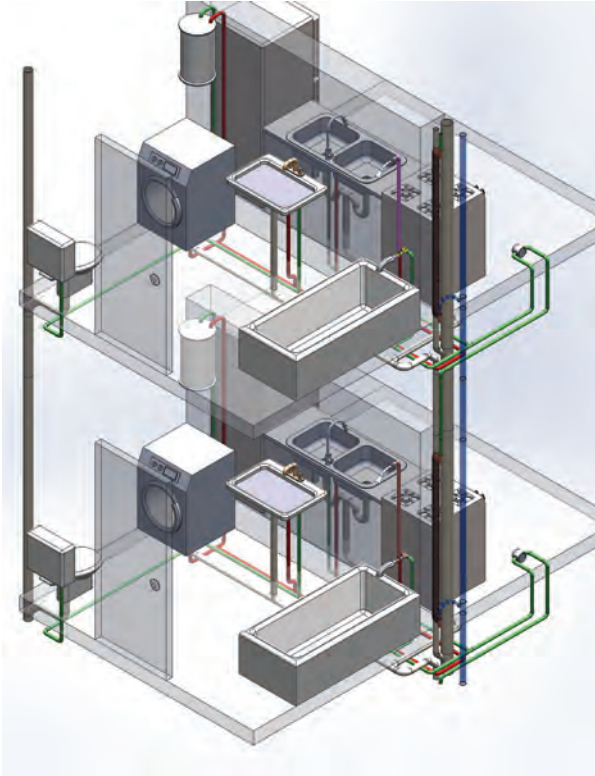

- 1x DWHR unit per Apartment
- Drain water runs parallel to main stack and through unit
- 2" diameter DWHR for grey water or 3" diameter DWHR for all drain water
- Each apartment with small 20 gallon wall-mounted water heater / off peak heating recommended with electric water heating
- Fresh water from DWHR to water heater and all cold water fixtures

## In-Building, Vertical, Stand-alone, Fresh water on recirc loop

- Measured Paybacks: 2 to 5 years
- Over 70 Systems in Operation over 15 years
- Very Low Maintenance
- Level 2 System - with Recirc. Loop

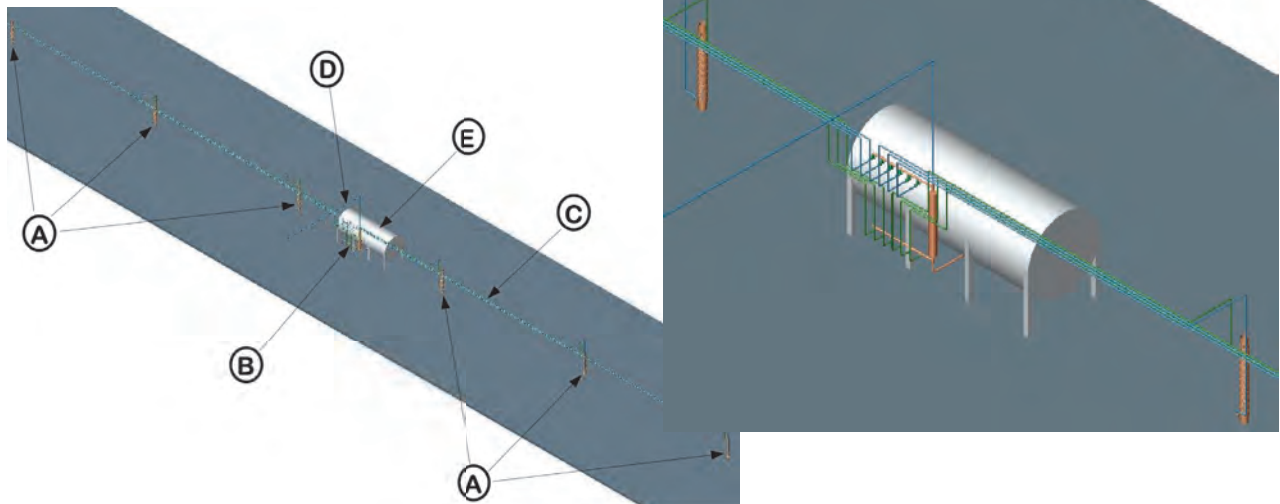

## Vertical, Passive, Multi-Pipe Power-Pipe Systems - Grey Water

- Flowrates: ~4gpm to 1,000s gpm
- Only permitted with Grey Water
- Minimal maintenance, Double-walled vented
- Many application types

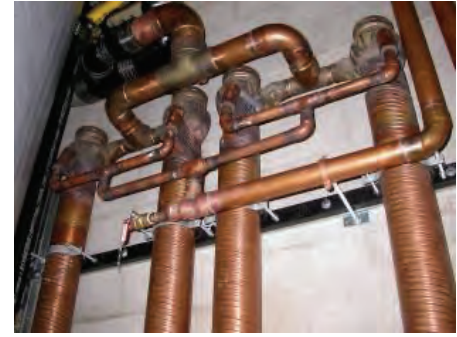

## Central Horizontal Systems - Small to Large Multi-Residential

- About 90 Systems installed in Multi-family and Hotels
- Recover heat from main drain (i.e. black water)
- Paybacks of 4 to 6 years are typical
- \$8K to \$20K Installed
- Configurations:

### Level 1 - Passive:

- Proven to reduce DHW Energy Load by 23% to 25%
- Preheats by about 20F° (12C°)

### Level 2 - Recirc. Loop:

- Reduces DHW Energy Load by 25% to 30%
- Preheats by about 22F° (13C°)

### Levels 3&4 - DSHP

- Drain Source Heat Pump for Water Heating and Space Conditioning



## Level 1: Completely Passive - Diversion of Drain through System

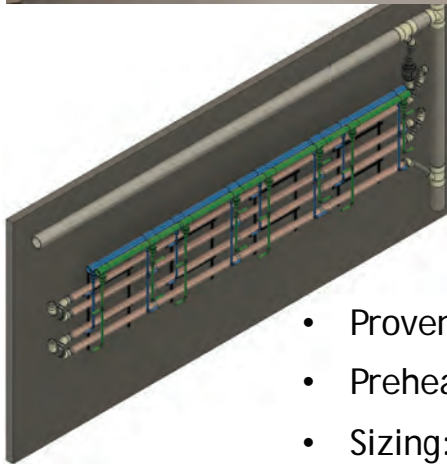

- Proven to reduce DHW Energy Load by 23% to 25%
- Preheats by about 20F° (12C°)
- Sizing: 8 inches per Apartment
- Potable Water is plumbed in "Cross-Flow" to Drain Water

## Level 1 - System to be installed in Quebec in 2026

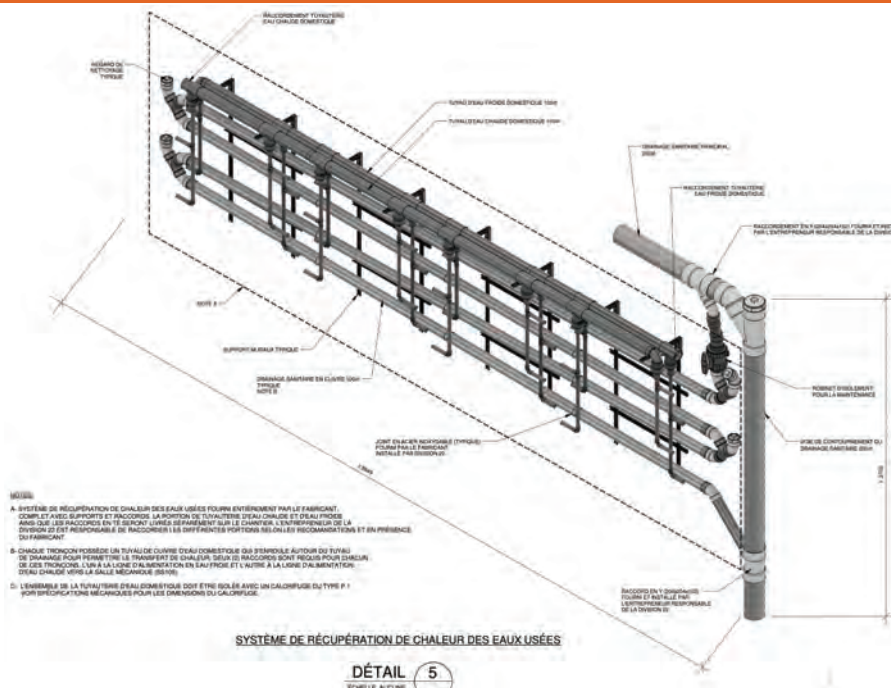

- Prefabricated system coming which stack like Lego and each have 2" Potable Water Connections

## Level 1 - 2023 Performance of Three Sample Installations

	Building 1	Building 2	Building 3
Occupancy Type	Couples/Families	Couples/Families	Couples/Families
Number of Apartments in Building	118	115	172
Number of Apartments Feeding Drain	118	97	172
Average	118	106	172
Number of Power-Pipes	8	6	8
Power-Pipe Model	C4-120	C4-120	C4-120
Year Installed or Building Occupied, whichever is later	2019	2021	2021
Hot Water Delivery Temperature [C]	55	55	55
Primary Water Heating Heat Exchanger Capacity [kW]	260	210	380
Power-Pipe Length [inches]	960	720	960
Power-Pipe Length Per Apartment [inches/apartment]	8.1	6.8	5.6
2023 Total Energy Delivery by Power-Pipe System [kWh]	59,100	48,700	68,300
2023 Total Hot Water Load [kWh]	236,500	data gaps	289,200
<b>2023 % Savings from Power-Pipe System</b>	<b>25.0%</b>	N/A	<b>23.6%</b>

## Level 1 - Building 1

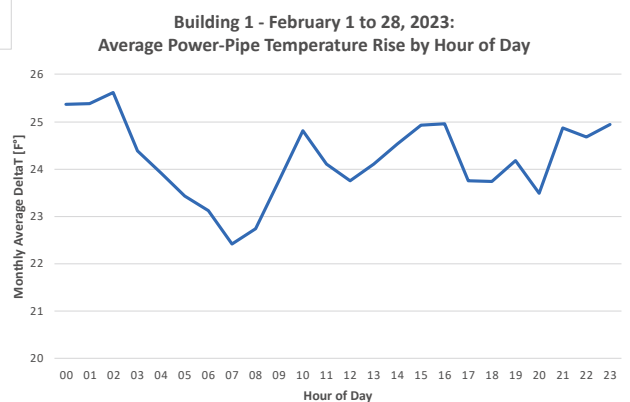
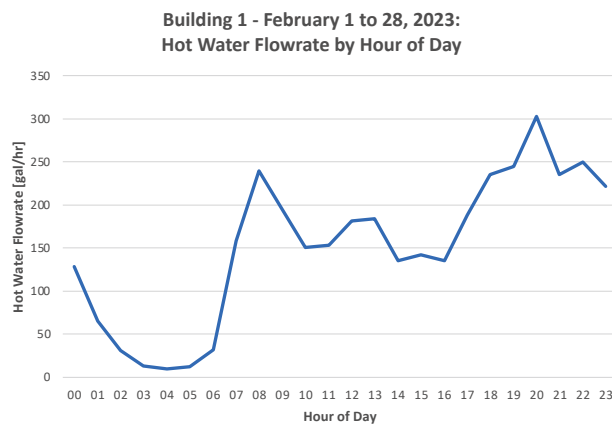

## Level 1 - Building 1 (cont.)

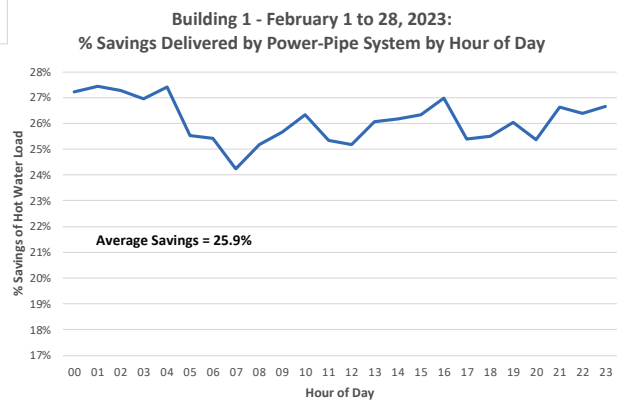
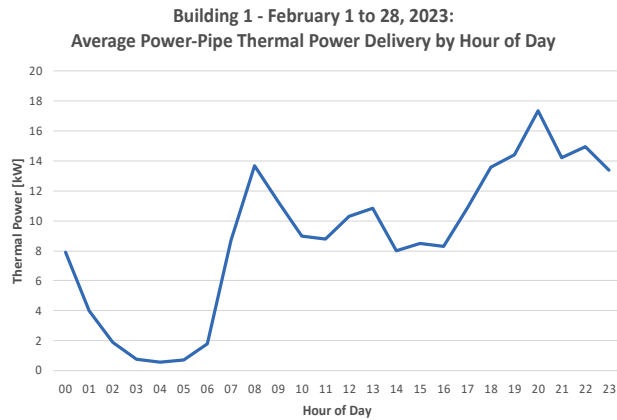

## Level 1 - Buildings 2 & 3

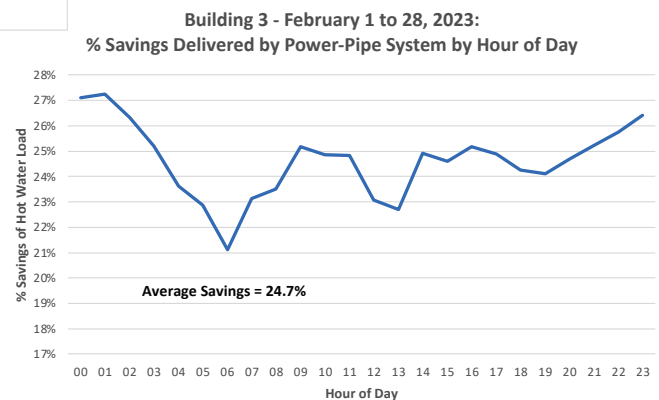
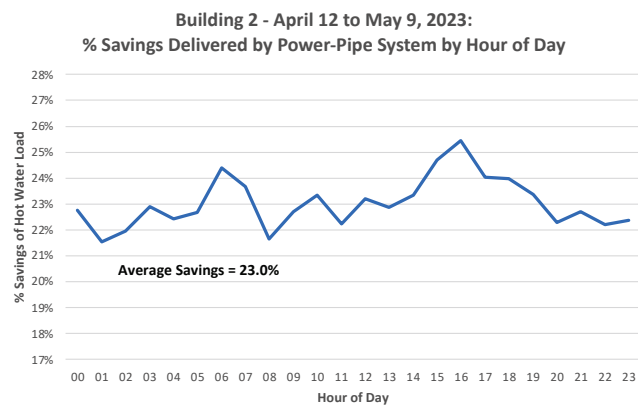

## Level 2: Pre-Fabricated Systems & Variable Speed Recirculation

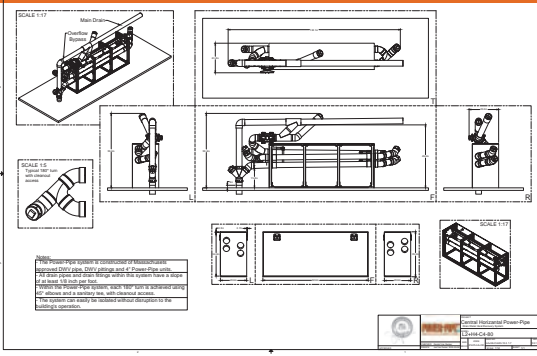

## Level 2: Daily Savings at 150&156 Washington St., Boston

- Monitoring by New Ecology, Inc. / Initial Analysis by G. Van Decker, P.Eng.
- Daily Percent Savings of Hot Water Energy Load - Nov 20 - Dec 9, 2025

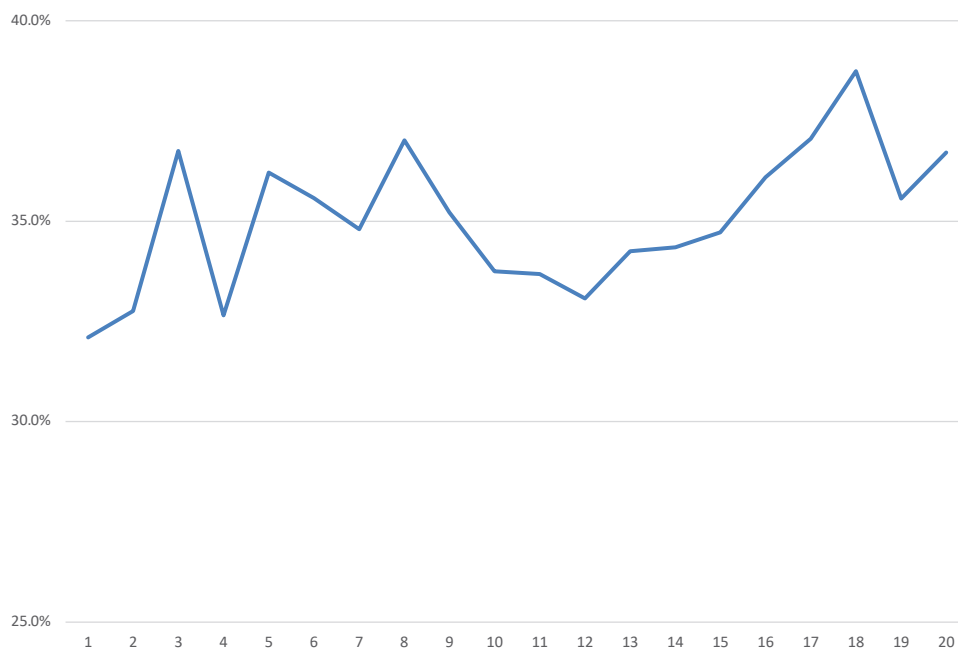

# Level 2: Standard "Plug and Play Design"

	Min.	Max.
L1 (1/2" Pipe)	22 1/2"	28 1/2"
L1 (3/4" Pipe)	23 1/2"	29 1/2"
L1 (1" Pipe)	24 1/2"	30 1/2"
L1 (1 1/2" Pipe)	25 1/2"	31 1/2"
L1 (2" Pipe)	26 1/2"	32 1/2"
L1 (2 1/2" Pipe)	27 1/2"	33 1/2"
L1 (3" Pipe)	28 1/2"	34 1/2"
L1 (3 1/2" Pipe)	29 1/2"	35 1/2"
L1 (4" Pipe)	30 1/2"	36 1/2"
L1 (4 1/2" Pipe)	31 1/2"	37 1/2"
L1 (5" Pipe)	32 1/2"	38 1/2"
L1 (5 1/2" Pipe)	33 1/2"	39 1/2"
L1 (6" Pipe)	34 1/2"	40 1/2"
L1 (6 1/2" Pipe)	35 1/2"	41 1/2"
L1 (7" Pipe)	36 1/2"	42 1/2"
L1 (7 1/2" Pipe)	37 1/2"	43 1/2"
L1 (8" Pipe)	38 1/2"	44 1/2"
L1 (8 1/2" Pipe)	39 1/2"	45 1/2"
L1 (9" Pipe)	40 1/2"	46 1/2"
L1 (9 1/2" Pipe)	41 1/2"	47 1/2"
L1 (10" Pipe)	42 1/2"	48 1/2"
L1 (10 1/2" Pipe)	43 1/2"	49 1/2"
L1 (11" Pipe)	44 1/2"	50 1/2"
L1 (11 1/2" Pipe)	45 1/2"	51 1/2"
L1 (12" Pipe)	46 1/2"	52 1/2"
L1 (12 1/2" Pipe)	47 1/2"	53 1/2"
L1 (13" Pipe)	48 1/2"	54 1/2"
L1 (13 1/2" Pipe)	49 1/2"	55 1/2"
L1 (14" Pipe)	50 1/2"	56 1/2"
L1 (14 1/2" Pipe)	51 1/2"	57 1/2"
L1 (15" Pipe)	52 1/2"	58 1/2"
L1 (15 1/2" Pipe)	53 1/2"	59 1/2"
L1 (16" Pipe)	54 1/2"	60 1/2"
L1 (16 1/2" Pipe)	55 1/2"	61 1/2"
L1 (17" Pipe)	56 1/2"	62 1/2"
L1 (17 1/2" Pipe)	57 1/2"	63 1/2"
L1 (18" Pipe)	58 1/2"	64 1/2"
L1 (18 1/2" Pipe)	59 1/2"	65 1/2"
L1 (19" Pipe)	60 1/2"	66 1/2"
L1 (19 1/2" Pipe)	61 1/2"	67 1/2"
L1 (20" Pipe)	62 1/2"	68 1/2"
L1 (20 1/2" Pipe)	63 1/2"	69 1/2"
L1 (21" Pipe)	64 1/2"	70 1/2"
L1 (21 1/2" Pipe)	65 1/2"	71 1/2"
L1 (22" Pipe)	66 1/2"	72 1/2"
L1 (22 1/2" Pipe)	67 1/2"	73 1/2"
L1 (23" Pipe)	68 1/2"	74 1/2"
L1 (23 1/2" Pipe)	69 1/2"	75 1/2"
L1 (24" Pipe)	70 1/2"	76 1/2"
L1 (24 1/2" Pipe)	71 1/2"	77 1/2"
L1 (25" Pipe)	72 1/2"	78 1/2"
L1 (25 1/2" Pipe)	73 1/2"	79 1/2"
L1 (26" Pipe)	74 1/2"	80 1/2"
L1 (26 1/2" Pipe)	75 1/2"	81 1/2"
L1 (27" Pipe)	76 1/2"	82 1/2"
L1 (27 1/2" Pipe)	77 1/2"	83 1/2"
L1 (28" Pipe)	78 1/2"	84 1/2"
L1 (28 1/2" Pipe)	79 1/2"	85 1/2"
L1 (29" Pipe)	80 1/2"	86 1/2"
L1 (29 1/2" Pipe)	81 1/2"	87 1/2"
L1 (30" Pipe)	82 1/2"	88 1/2"
L1 (30 1/2" Pipe)	83 1/2"	89 1/2"
L1 (31" Pipe)	84 1/2"	90 1/2"
L1 (31 1/2" Pipe)	85 1/2"	91 1/2"
L1 (32" Pipe)	86 1/2"	92 1/2"
L1 (32 1/2" Pipe)	87 1/2"	93 1/2"
L1 (33" Pipe)	88 1/2"	94 1/2"
L1 (33 1/2" Pipe)	89 1/2"	95 1/2"
L1 (34" Pipe)	90 1/2"	96 1/2"
L1 (34 1/2" Pipe)	91 1/2"	97 1/2"
L1 (35" Pipe)	92 1/2"	98 1/2"
L1 (35 1/2" Pipe)	93 1/2"	99 1/2"
L1 (36" Pipe)	94 1/2"	100 1/2"
L1 (36 1/2" Pipe)	95 1/2"	101 1/2"
L1 (37" Pipe)	96 1/2"	102 1/2"
L1 (37 1/2" Pipe)	97 1/2"	103 1/2"
L1 (38" Pipe)	98 1/2"	104 1/2"
L1 (38 1/2" Pipe)	99 1/2"	105 1/2"
L1 (39" Pipe)	100 1/2"	106 1/2"
L1 (39 1/2" Pipe)	101 1/2"	107 1/2"
L1 (40" Pipe)	102 1/2"	108 1/2"
L1 (40 1/2" Pipe)	103 1/2"	109 1/2"
L1 (41" Pipe)	104 1/2"	110 1/2"
L1 (41 1/2" Pipe)	105 1/2"	111 1/2"
L1 (42" Pipe)	106 1/2"	112 1/2"
L1 (42 1/2" Pipe)	107 1/2"	113 1/2"
L1 (43" Pipe)	108 1/2"	114 1/2"
L1 (43 1/2" Pipe)	109 1/2"	115 1/2"
L1 (44" Pipe)	110 1/2"	116 1/2"
L1 (44 1/2" Pipe)	111 1/2"	117 1/2"
L1 (45" Pipe)	112 1/2"	118 1/2"
L1 (45 1/2" Pipe)	113 1/2"	119 1/2"
L1 (46" Pipe)	114 1/2"	120 1/2"
L1 (46 1/2" Pipe)	115 1/2"	121 1/2"
L1 (47" Pipe)	116 1/2"	122 1/2"
L1 (47 1/2" Pipe)	117 1/2"	123 1/2"
L1 (48" Pipe)	118 1/2"	124 1/2"
L1 (48 1/2" Pipe)	119 1/2"	125 1/2"
L1 (49" Pipe)	120 1/2"	126 1/2"
L1 (49 1/2" Pipe)	121 1/2"	127 1/2"
L1 (50" Pipe)	122 1/2"	128 1/2"
L1 (50 1/2" Pipe)	123 1/2"	129 1/2"
L1 (51" Pipe)	124 1/2"	130 1/2"
L1 (51 1/2" Pipe)	125 1/2"	131 1/2"
L1 (52" Pipe)	126 1/2"	132 1/2"
L1 (52 1/2" Pipe)	127 1/2"	133 1/2"
L1 (53" Pipe)	128 1/2"	134 1/2"
L1 (53 1/2" Pipe)	129 1/2"	135 1/2"
L1 (54" Pipe)	130 1/2"	136 1/2"
L1 (54 1/2" Pipe)	131 1/2"	137 1/2"
L1 (55" Pipe)	132 1/2"	138 1/2"
L1 (55 1/2" Pipe)	133 1/2"	139 1/2"
L1 (56" Pipe)	134 1/2"	140 1/2"
L1 (56 1/2" Pipe)	135 1/2"	141 1/2"
L1 (57" Pipe)	136 1/2"	142 1/2"
L1 (57 1/2" Pipe)	137 1/2"	143 1/2"
L1 (58" Pipe)	138 1/2"	144 1/2"
L1 (58 1/2" Pipe)	139 1/2"	145 1/2"
L1 (59" Pipe)	140 1/2"	146 1/2"
L1 (59 1/2" Pipe)	141 1/2"	147 1/2"
L1 (60" Pipe)	142 1/2"	148 1/2"
L1 (60 1/2" Pipe)	143 1/2"	149 1/2"
L1 (61" Pipe)	144 1/2"	150 1/2"
L1 (61 1/2" Pipe)	145 1/2"	151 1/2"
L1 (62" Pipe)	146 1/2"	152 1/2"
L1 (62 1/2" Pipe)	147 1/2"	153 1/2"
L1 (63" Pipe)	148 1/2"	154 1/2"
L1 (63 1/2" Pipe)	149 1/2"	155 1/2"
L1 (64" Pipe)	150 1/2"	156 1/2"
L1 (64 1/2" Pipe)	151 1/2"	157 1/2"
L1 (65" Pipe)	152 1/2"	158 1/2"
L1 (65 1/2" Pipe)	153 1/2"	159 1/2"
L1 (66" Pipe)	154 1/2"	160 1/2"
L1 (66 1/2" Pipe)	155 1/2"	161 1/2"
L1 (67" Pipe)	156 1/2"	162 1/2"
L1 (67 1/2" Pipe)	157 1/2"	163 1/2"
L1 (68" Pipe)	158 1/2"	164 1/2"
L1 (68 1/2" Pipe)	159 1/2"	165 1/2"
L1 (69" Pipe)	160 1/2"	166 1/2"
L1 (69 1/2" Pipe)	161 1/2"	167 1/2"
L1 (70" Pipe)	162 1/2"	168 1/2"
L1 (70 1/2" Pipe)	163 1/2"	169 1/2"
L1 (71" Pipe)	164 1/2"	170 1/2"
L1 (71 1/2" Pipe)	165 1/2"	171 1/2"
L1 (72" Pipe)	166 1/2"	172 1/2"
L1 (72 1/2" Pipe)	167 1/2"	173 1/2"
L1 (73" Pipe)	168 1/2"	174 1/2"
L1 (73 1/2" Pipe)	169 1/2"	175 1/2"
L1 (74" Pipe)	170 1/2"	176 1/2"
L1 (74 1/2" Pipe)	171 1/2"	177 1/2"
L1 (75" Pipe)	172 1/2"	178 1/2"
L1 (75 1/2" Pipe)	173 1/2"	179 1/2"
L1 (76" Pipe)	174 1/2"	180 1/2"
L1 (76 1/2" Pipe)	175 1/2"	181 1/2"
L1 (77" Pipe)	176 1/2"	182 1/2"
L1 (77 1/2" Pipe)	177 1/2"	183 1/2"
L1 (78" Pipe)	178 1/2"	184 1/2"
L1 (78 1/2" Pipe)	179 1/2"	185 1/2"
L1 (79" Pipe)	180 1/2"	186 1/2"
L1 (79 1/2" Pipe)	181 1/2"	187 1/2"
L1 (80" Pipe)	182 1/2"	188 1/2"
L1 (80 1/2" Pipe)	183 1/2"	189 1/2"
L1 (81" Pipe)	184 1/2"	190 1/2"
L1 (81 1/2" Pipe)	185 1/2"	191 1/2"
L1 (82" Pipe)	186 1/2"	192 1/2"
L1 (82 1/2" Pipe)	187 1/2"	193 1/2"
L1 (83" Pipe)	188 1/2"	194 1/2"
L1 (83 1/2" Pipe)	189 1/2"	195 1/2"
L1 (84" Pipe)	190 1/2"	196 1/2"
L1 (84 1/2" Pipe)	191 1/2"	197 1/2"
L1 (85" Pipe)	192 1/2"	198 1/2"
L1 (85 1/2" Pipe)	193 1/2"	199 1/2"
L1 (86" Pipe)	194 1/2"	200 1/2"
L1 (86 1/2" Pipe)	195 1/2"	201 1/2"
L1 (87" Pipe)	196 1/2"	202 1/2"
L1 (87 1/2" Pipe)	197 1/2"	203 1/2"
L1 (88" Pipe)	198 1/2"	204 1/2"
L1 (88 1/2" Pipe)	199 1/2"	205 1/2"
L1 (89" Pipe)	200 1/2"	206 1/2"
L1 (89 1/2" Pipe)	201 1/2"	207 1/2"
L1 (90" Pipe)	202 1/2"	208 1/2"
L1 (90 1/2" Pipe)	203 1/2"	209 1/2"
L1 (91" Pipe)	204 1/2"	210 1/2"
L1 (91 1/2" Pipe)	205 1/2"	211 1/2"
L1 (92" Pipe)	206 1/2"	212 1/2"
L1 (92 1/2" Pipe)	207 1/2"	213 1/2"
L1 (93" Pipe)	208 1/2"	214 1/2"
L1 (93 1/2" Pipe)	209 1/2"	215 1/2"
L1 (94" Pipe)	210 1/2"	216 1/2"
L1 (94 1/2" Pipe)	211 1/2"	217 1/2"
L1 (95" Pipe)	212 1/2"	218 1/2"
L1 (95 1/2" Pipe)	213 1/2"	219 1/2"
L1 (96" Pipe)	214 1/2"	220 1/2"
L1 (96 1/2" Pipe)	215 1/2"	221 1/2"
L1 (97" Pipe)	216 1/2"	222 1/2"
L1 (97 1/2" Pipe)	217 1/2"	223 1/2"
L1 (98" Pipe)	218 1/2"	224 1/2"
L1 (98 1/2" Pipe)	219 1/2"	225 1/2"
L1 (99" Pipe)	220 1/2"	226 1/2"
L1 (99 1/2" Pipe)	221 1/2"	227 1/2"
L1 (100" Pipe)	222 1/2"	228 1/2"
L1 (100 1/2" Pipe)	223 1/2"	229 1/2"
L1 (101" Pipe)	224 1/2"	230 1/2"
L1 (101 1/2" Pipe)	225 1/2"	231 1/2"
L1 (102" Pipe)	226 1/2"	232 1/2"
L1 (102 1/2" Pipe)	227 1/2"	233 1/2"
L1 (103" Pipe)	228 1/2"	234 1/2"
L1 (103 1/2" Pipe)	229 1/2"	235 1/2"
L1 (104" Pipe)	230 1/2"	236 1/2"
L1 (104 1/2" Pipe)	231 1/2"	237 1/2"
L1 (105" Pipe)	232 1/2"	238 1/2"
L1 (105 1/2" Pipe)	233 1/2"	239 1/2"
L1 (106" Pipe)	234 1/2"	240 1/2"
L1 (106 1/2" Pipe)	235 1/2"	241 1/2"
L1 (107" Pipe)	236 1/2"	242 1/2"
L1 (107 1/2" Pipe)	237 1/2"	243 1/2"
L1 (108" Pipe)	238 1/2"	244 1/2"
L1 (108 1/2" Pipe)	239 1/2"	245 1/2"
L1 (109" Pipe)	240 1/2"	246 1/2"
L1 (109 1/2" Pipe)	241 1/2"	247 1/2"
L1 (110" Pipe)	242 1/2"	248 1/2"
L1 (110 1/2" Pipe)	243 1/2"	249 1/2"
L1 (111" Pipe)	244 1/2"	250 1/2"
L1 (111 1/2" Pipe)	245 1/2"	251 1/2"
L1 (112" Pipe)	246 1/2"	252 1/2"
L1 (112 1/2" Pipe)	247 1/2"	253 1/2"
L1 (113" Pipe)	248 1/2"	254 1/2"
L1 (113 1/2" Pipe)	249 1/2"	255 1/2"
L1 (114" Pipe)	250 1/2"	256 1/2"
L1 (114 1/2" Pipe)	251 1/2"	257 1/2"
L1 (115" Pipe)	252 1/2"	258 1/2"
L1 (115 1/2" Pipe)	253 1/2"	259 1/2"
L1 (116" Pipe)	254 1/2"	260 1/2"
L1 (116 1/2" Pipe)	255 1/2"	261 1/2"
L1 (117" Pipe)	256 1/2"	262 1/2"
L1 (117 1/2" Pipe)	257 1/2"	263 1/2"
L1 (118" Pipe)	258 1/2"	264 1/2"
L1 (118 1/2" Pipe)	259 1/2"	265 1/2"
L1 (119" Pipe)	260 1/2"	266 1/2"
L1 (119 1/2" Pipe)	261 1/2"	267 1/2"
L1 (120" Pipe)	262 1/2"	268 1/2"
L1 (120 1/2" Pipe)	263 1/2"	269 1/2"
L1 (121" Pipe)	264 1/2"	270 1/2"
L1 (121 1/2" Pipe)	265 1/2"	271 1/2"
L1 (122" Pipe)	266 1/2"	272 1/2"
L1 (122 1/2" Pipe)	267 1/2"	273 1/2"
L1 (123" Pipe)	268 1/2"	274 1/2"
L1 (123 1/2" Pipe)	269 1/2"	275 1/2"
L1 (124" Pipe)	270 1/2"	276 1/2"
L1 (124 1/2" Pipe)	271 1/2"	277 1/2"
L1 (125" Pipe)	272 1/2"	278 1/2"
L1 (125 1/2" Pipe)	273 1/2"	279 1/2"
L1 (126" Pipe)	274 1/2"	280 1/2"
L1 (126 1/2" Pipe)	275 1/2"	281 1/2"
L1 (127" Pipe)	276 1/2"	282 1/2"
L1 (127 1/2" Pipe)	277 1/2"	283 1/2"
L1 (128" Pipe)	278 1/2"	284 1/2"
L1 (128 1/2" Pipe)	279 1/2"	285 1/2"
L1 (129" Pipe)	280 1/2"	286 1/2"
L1 (129 1/2" Pipe)	281 1/2"	287 1/2"
L1 (130" Pipe)	282 1/2"	288 1/2"
L1 (130 1/2" Pipe)	283 1/2	

## Level 2: Recirc Loop and Preheats by about 22-24F° (13-14C°)



- Plumbed for Counter-Flow
- Reduce DHW Energy Load by 25% to 28%
- Requires a Variable Speed controlled Booster Pump
- About the same cost as Level 1
- Future Proofing:  
    "Drain Source Heat Pump Ready" for Levels 3 & 4

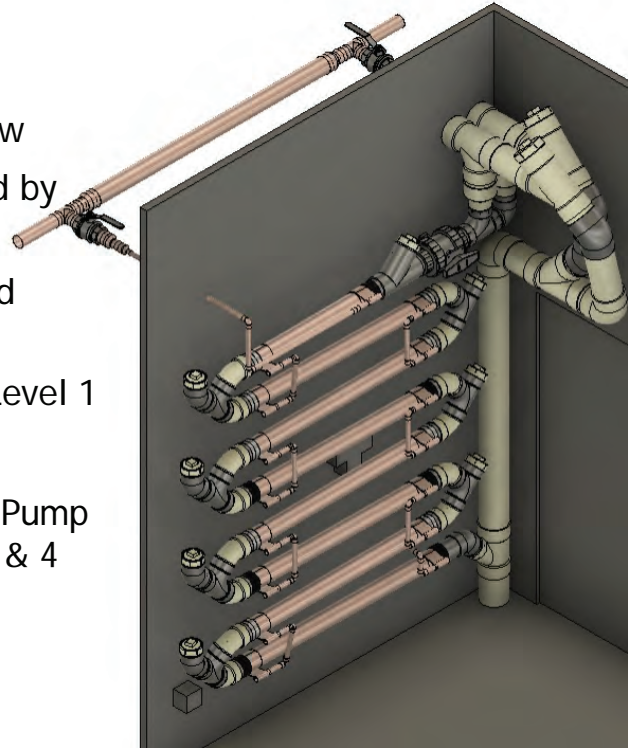

## Level 2: Showing Booster Pump and Buffer Thermal Storage

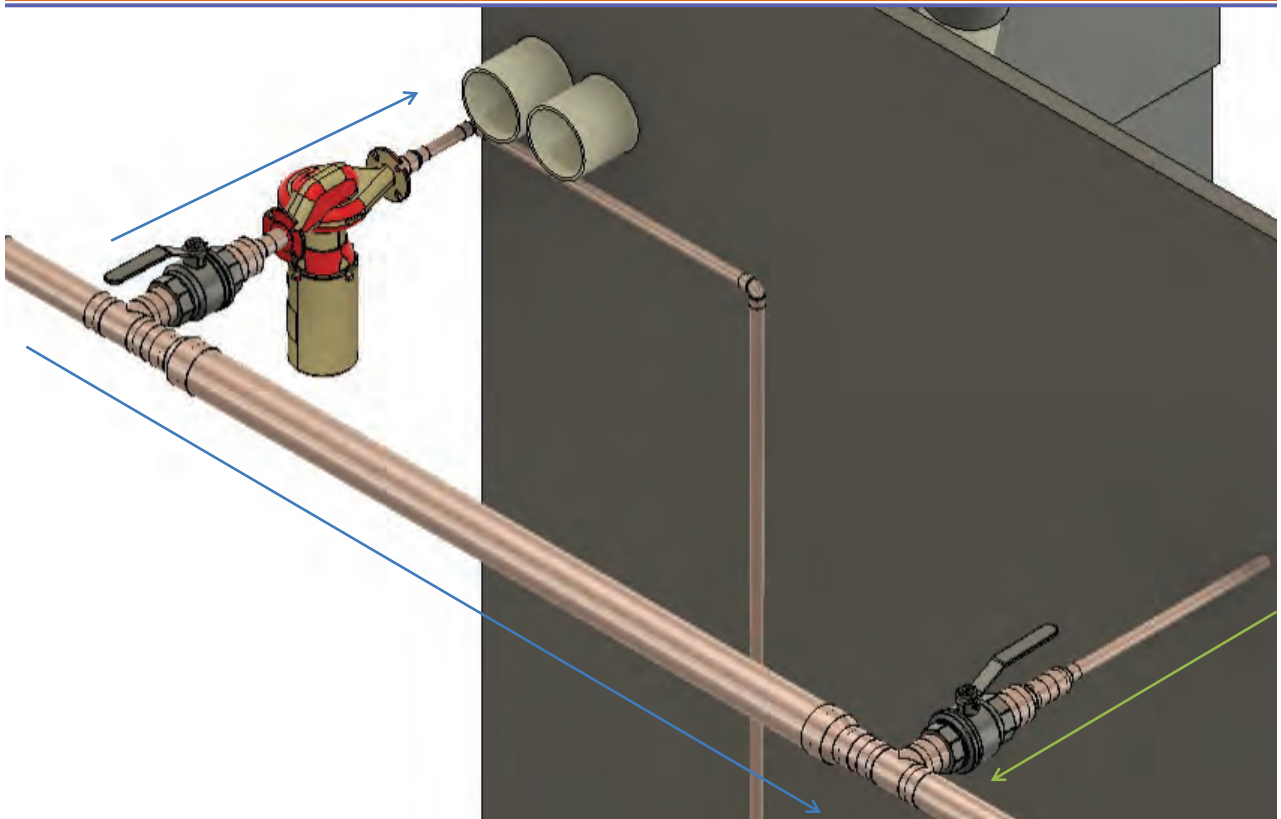

## Level 2 - Vary by # of Power-Pipe and Length

- L2+H6-I4-120 - Typically 75 to 100 Suite Building

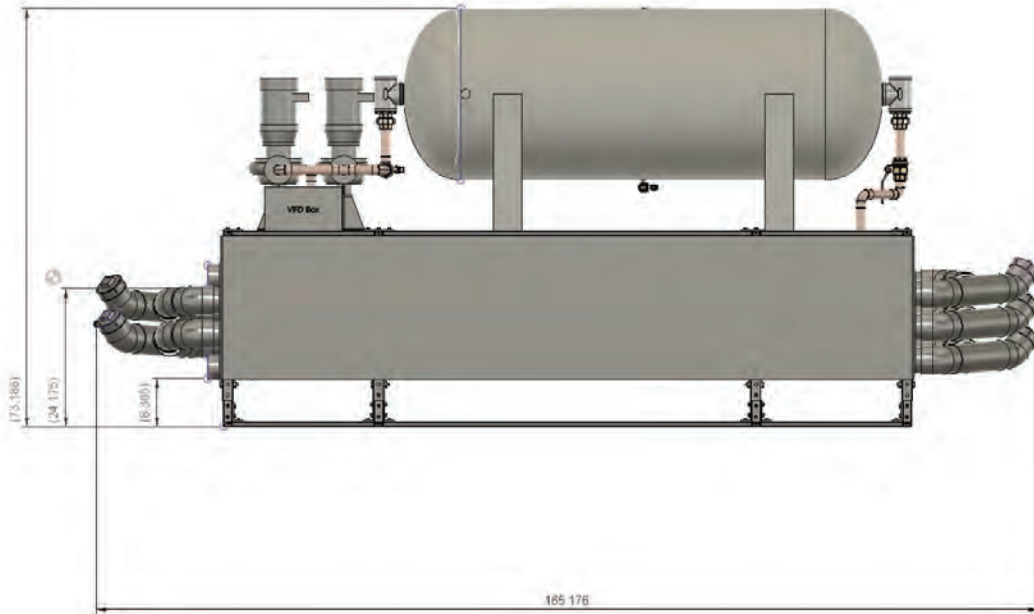

## Level 2 - Vary by # of Power-Pipe and Length

- Fully Extended Base

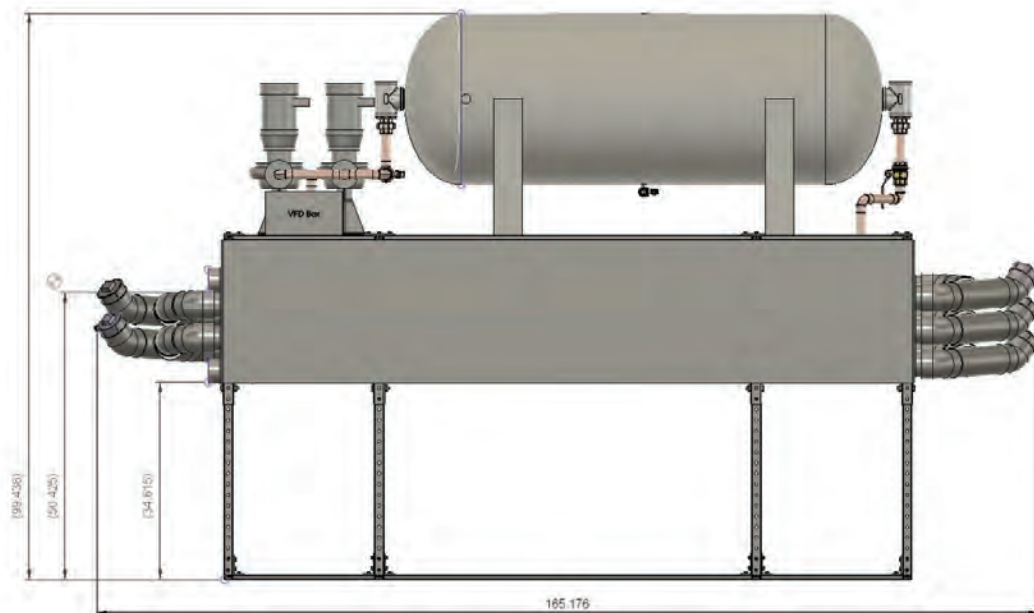

## Level 2 - Many Pre-Fabricated, Plug and Play Packages

- Every element complies to plumbing code

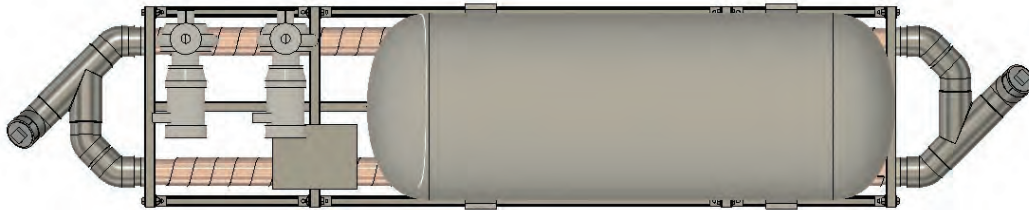

## Level 2 (continued)

- Retrofit in 118 Unit Multi-Unit Residential Building
- Two separate 6inch Power-Pipe Systems, each on a recirc. loop

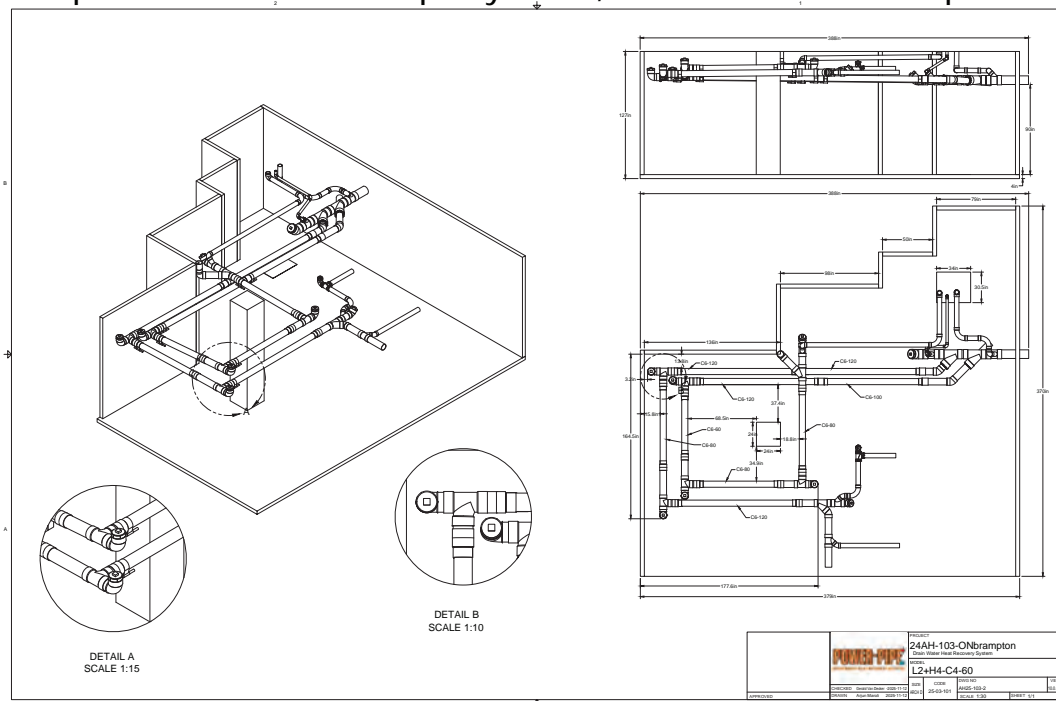

## Level 3: Drain Source Heat Pump (DSHP) Water Heating

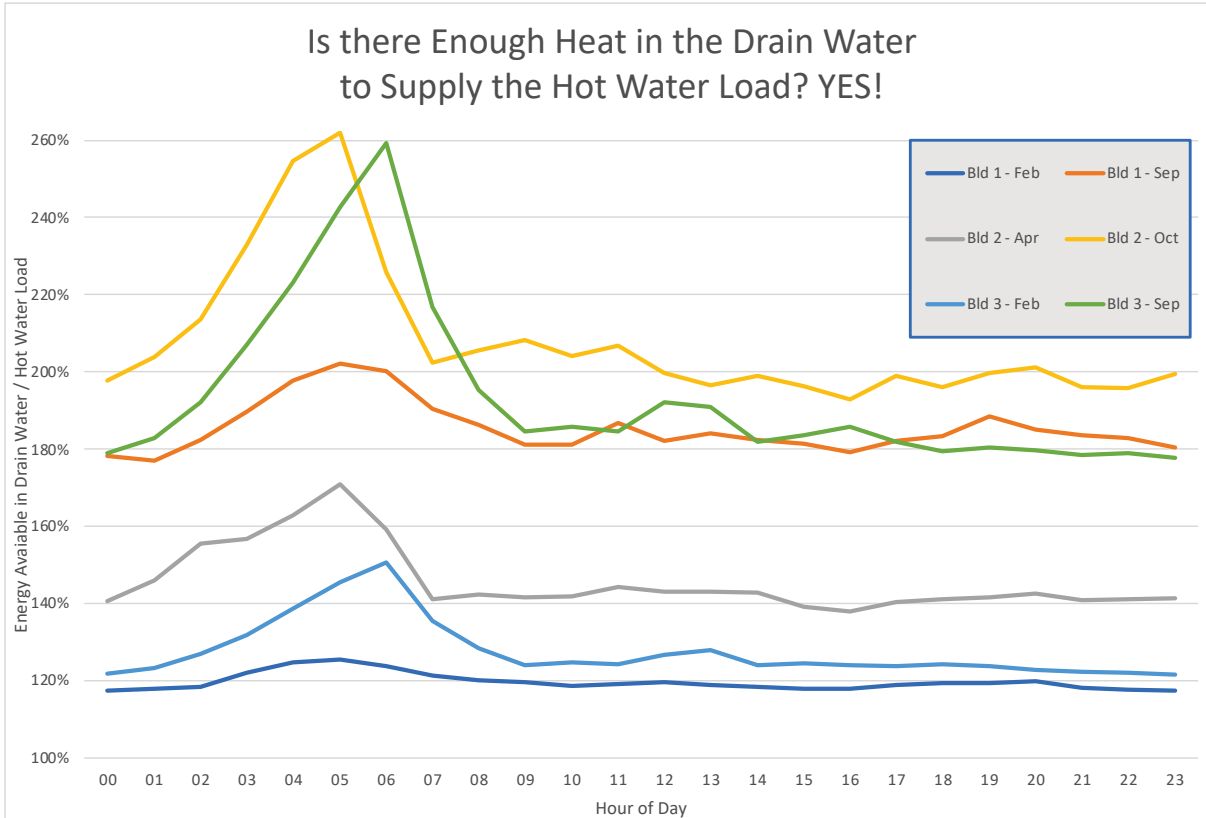

## Level 3: DSHP Water Heating

- Water Source Heat Pump(s) are used but with bespoke controls
- Large Potable "Pre-heat" Thermal Storage is Required
- Uses same DWHR Design as with Level 2

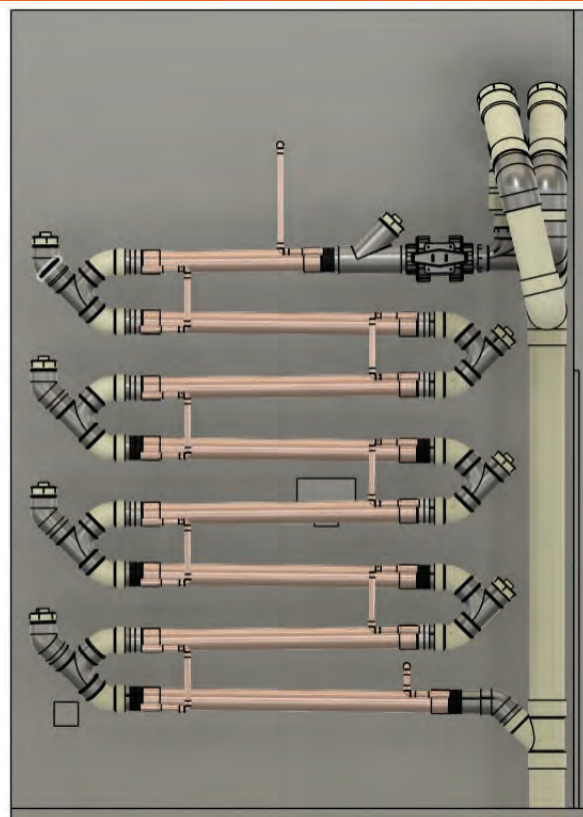

## Level 3: Sampling of Recent Research by ORNL

### Cost Reduction of Heat Pump Water Heating in Cold Climates for Low to Moderate Income Families

<https://www.ornl.gov/publication/cost-reduction-heat-pump-water-heating-cold-climates-low-moderate-income-families>

same as above: <https://docs.lib.purdue.edu/cgi/viewcontent.cgi?article=1465&context=ihpbc>

### Performance Evaluation of Drain Water Heat Recovery Exchangers for Heat Pump Water Heaters

<https://www.ornl.gov/publication/performance-evaluation-drain-water-heat-recovery-exchangers-heat-pump-water-heaters>

same as above: <https://docs.lib.purdue.edu/cgi/viewcontent.cgi?article=3635&context=iracc>

### Cost Compression of Heat Pump Water Heaters for Multifamily Housing in Cold Climates (CC HPWH MH CC) (2024)

<https://www.ornl.gov/publication/performance-evaluation-drain-water-heat-recovery-exchangers-heat-pump-water-heaters>

## Level 4: DSHP Water Heating & Space Conditioning

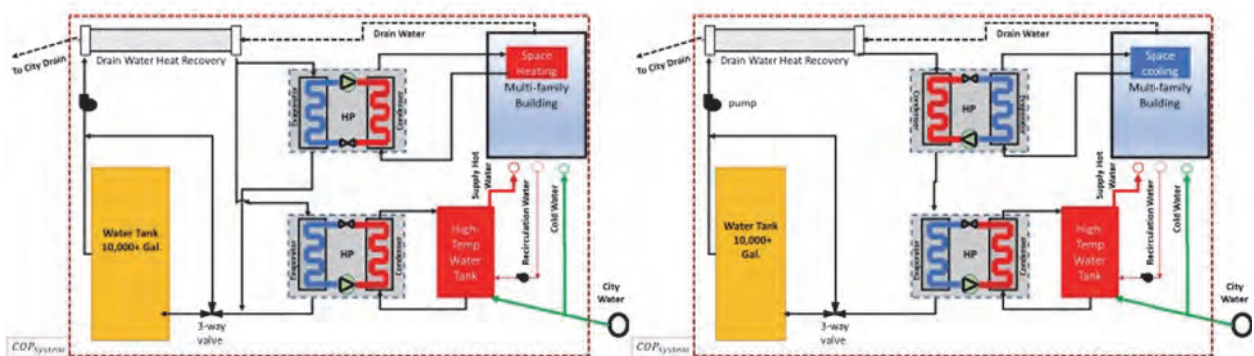

- Credit: Schematic from Oakridge National Lab
- Space Heating on Left:
  - From field data, there is still surplus heat in the drain (in addition to hot water load)
- Space Cooling on Right:
  - 1<sup>st</sup>: Dump heat from Common Spaces into Power-Pipe line via WS Heat Pump
  - 2<sup>nd</sup>: Then Extract from Power-Pipe line to produce Domestic Hot Water via WS Heat Pump

## Level 4: DSHP Water Heating & Space Conditioning (Cooling)

- Credit: Graph from Oakridge National Lab
- Potential combined system performance
- It is an excellent fit to combine both loads in one integrated system

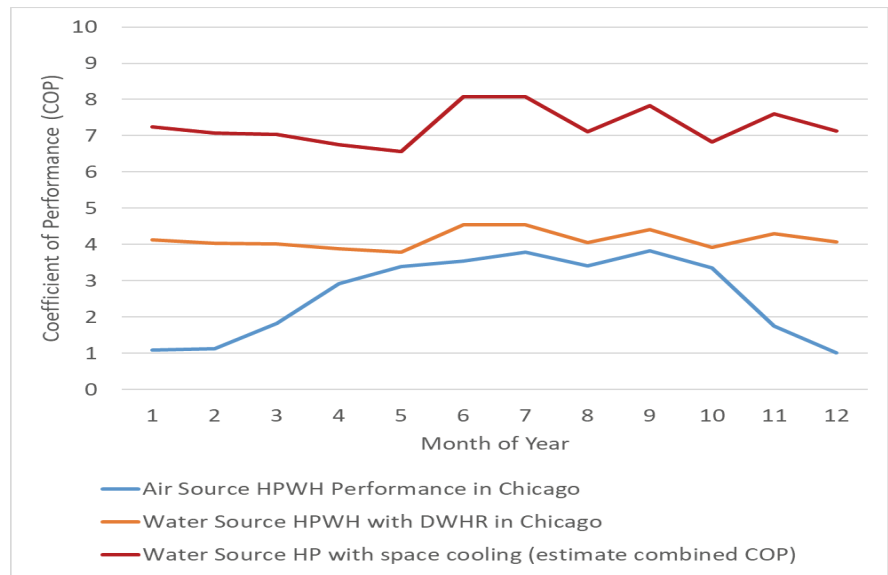

Thank you for Attending. Questions?



500 Trillium Drive - Unit #21  
Kitchener, Ontario, Canada  
N2R 1E5

Tel: (519)885-0283

[www.RenewABILITY.com](http://www.RenewABILITY.com)

By: Gerald Van Decker, M.A.Sc., P.Eng.  
gerald@renewability.com